



16 Input/16 Output DC Block I/O Module

Cat. No. 1791-16BC Series B

Installation

Mount the block I/O module in a vertical (recommended) or horizontal position. Allow sufficient room around the block for cooling air to flow through the block module. Refer to Figure 1.

Figure 1
Mounting Dimensions for the Block I/O Module
Cat. No. 1791-16BC (PLC version shown)

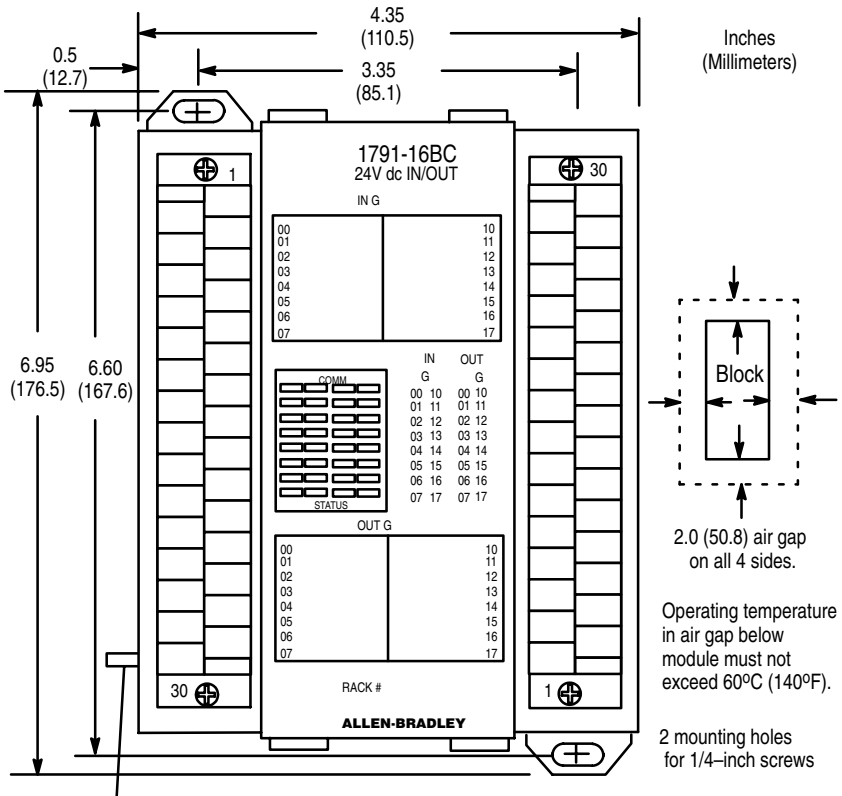

Equipment Grounding Stud

CAUTION: When tightening grounding stud nut, do not exceed 15 in-lbs.

Dimensions

6.95H x 4.35W x 3.85D
(176.5H x 110.5W x 98D)

Figure 2
Mounting on a DIN Rail

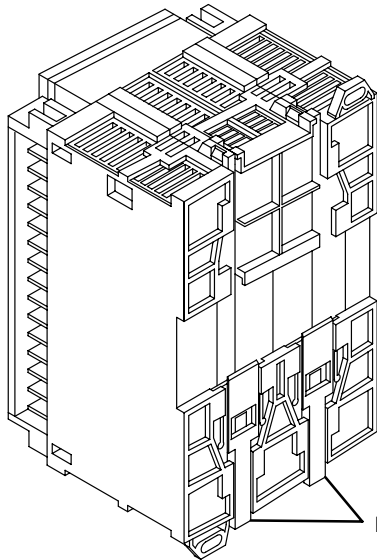

DIN Rail

A-B Pt. No. 199-DR1
46277-3
EN 50022
(35 x 7.5mm)

1. Hook top of slot over DIN rail.
2. While pressing block against rail, pull down on locking levers.
3. When block is flush against rail, push up on locking levers to secure block to rail.

Locking levers

Figure 3
Inserting Labels

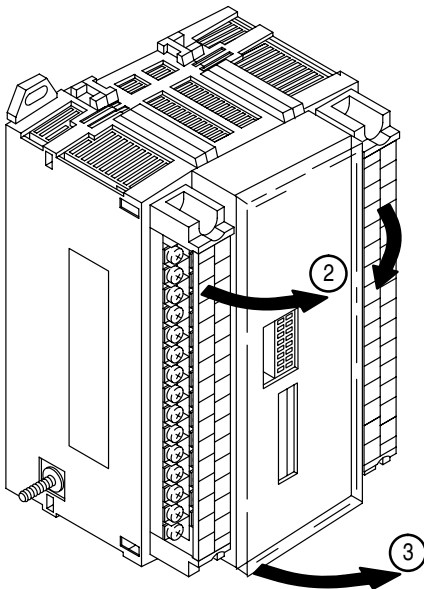

A set of labels is supplied with your module. Select the proper module designation labels (PLC or SLC) for the front door and terminal strips.

1. Remove die-cut labels from package. Select correct labels for your application. (PLC label is numbered 00–07 and 10–17. SLC is numbered 00–07 and 08–15.)
2. Remove plastic cover on terminal strip by flexing in middle. Slip terminal designation label with power and RIO designations into built-in holders in left terminal strip cover. Flex cover slightly to install. Repeat for the other terminal strip using the remaining label.
3. Open clear front door. Insert module designation label into slots in door.

Table A
Acceptable Wiring Cables for Block I/O Connection

Use	Cable Type
Remote I/O link	Belden 9463
Input and output wiring	Up to 14AWG (2mm ²) stranded with 3/64 inch insulation

Connect wiring as shown in Figure 4 or Figure 5.

Figure 4
Wiring Connections with PLC Family Programmable Controllers (refer to Table B)

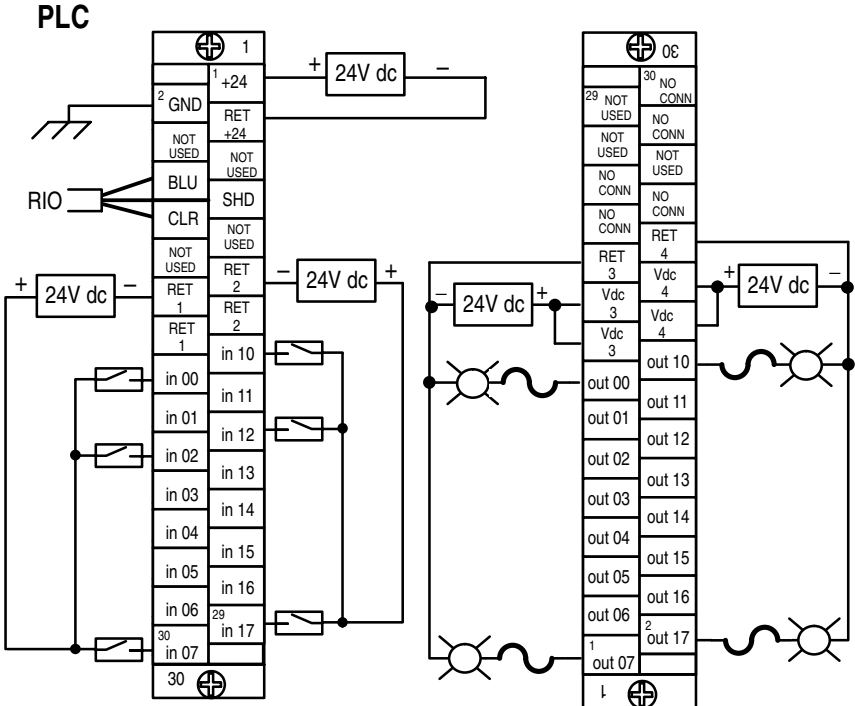

NOTE: RET 1 connections are internally connected.
 RET 2 connections are internally connected.
 Vdc 3 connections must be externally connected together to accommodate total amperage rating.
 Vdc 4 connections must be externally connected together to accommodate total amperage rating.
 Output fusing is recommended. Refer to Table C.

Figure 5
Wiring Connections with SLC Family Processors (refer to Table B)

SLC

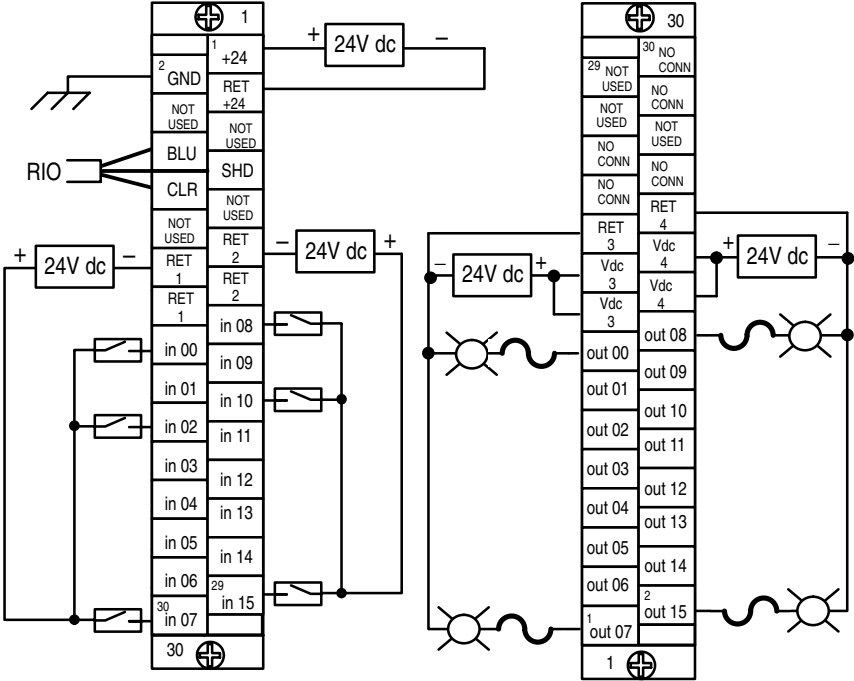

NOTE: RET 1 connections are internally connected.
 RET 2 connections are internally connected.
 Vdc 3 connections must be externally connected together to accommodate total amperage rating.
 Vdc 4 connections must be externally connected together to accommodate total amperage rating.
 Output fusing is recommended. Refer to Table C.

The block I/O module has an equipment grounding stud on the lower left side of the module. Connect this grounding stud to your equipment ground. Torque the nut to 15 in-lbs maximum when connecting to your equipment ground.



ATTENTION: Do not overtighten the nut on the grounding stud when connecting the wire. Damage to the module could result.

Refer to “Programmable Controller Wiring and Grounding Guidelines” (1770-4.1) for further information.

Table B
Wiring Block Designations

Connections	1791-16BC Series B		Connector/Terminal	
	Designation	Description	Left	Right
Power Connections	+24	+24V dc Power	1	
	RET +24	dc Return	3	
	GND	Chassis ground	2 ¹	
Remote I/O Connections	BLU	Blue wire – RIO	6	
	CLR	Clear wire – RIO	8	
	SHD	Shield – RIO	7	
I/O Connections				
Input (G) ⁶	PLC: in 00 thru 07 SLC: in 00 thru 07	PLC: Input 00 thru 07 SLC: Input 00 thru 07	16, 18, 20, 22, 24, 26, 28, 30	
	RET 1	dc input return	12, 14 ²	
	PLC: in 10 thru 17 SLC: in 08 thru 15	PLC: Input 10 thru 17 SLC: Input 08 thru 15	15, 17, 19, 21, 23, 25, 27, 29	
	RET 2	dc input return	11, 13 ³	
Output (G) ⁷	PLC: out 00 thru 07 SLC: out 00 thru 07	PLC: Output 00 thru 07 SLC: Output 00 thru 07		15, 13, 11, 9, 7, 5, 3, 1
	Vdc 3	+24V dc output supply		19, 17 ⁴
	RET 3	dc output return		21
	PLC: out 10 thru 17 SLC: out 08 thru 15	PLC: Output 10 thru 17 SLC: Output 08 thru 15		16, 14, 12, 10, 8, 6, 4, 2
	Vdc 4	+24V dc output supply		20, 18 ⁵
	RET 4	dc output return		22
	Not used	For internal test only; not for customer use.	4, 5, 9, 10	29, 27, 26
	No Conn	No internal connection; customer can use.		30, 28, 25, 24, 23

¹ Connect chassis ground to equipment grounding stud. These are not internally connected.

² Terminals 12 and 14 are internally connected.

³ Terminals 11 and 13 are internally connected.

⁴ Terminals 17 and 19 must be externally connected by customer to accommodate amperage rating.

⁵ Terminals 20 and 18 must be externally connected by customer to accommodate amperage rating.

⁶ IN (G) = input module group.

⁷ OUT (G) = output module group.

Figure 6
Switch Settings

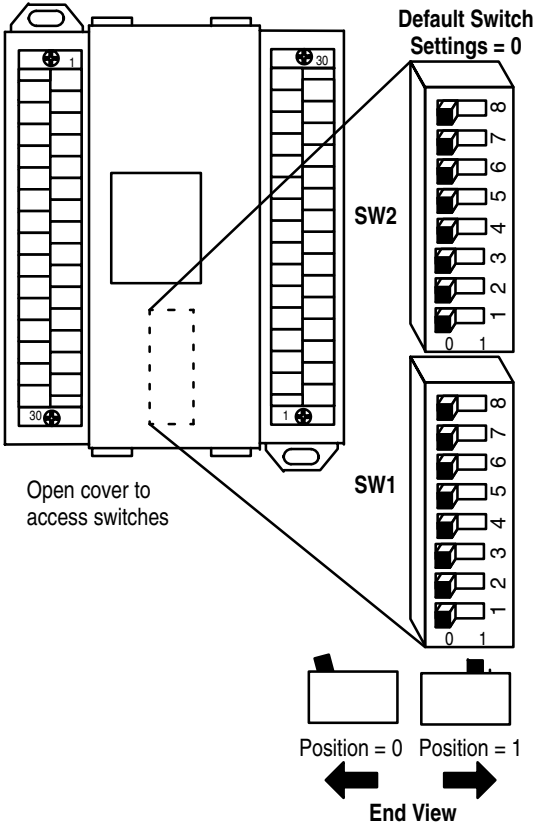

ATTENTION: Cycle power to the module after setting the switches.

SW2-8
Not used

SW2-7	Filter Speed Select (Inputs only)
0	Slow
1	Fast

SW2-6	Last I/O Group (PLC-2 only)
0	Not last rack
1	Last rack

SW2-5	Processor Restart/Lockout (PRL)
0	Processor Restart
1	Processor Lockout

SW2-4	Hold Last State
0	Reset Outputs
1	Hold Last State

SW2-3
Set to 0

Communication Rate		
SW2-2	SW2-1	Bits/s
0	0	57.6 K
0	1	115.2 K
1	0	230.4 K
1	1	230.4 K

Starting Quarter		
SW1-2	SW1-1	Module Group
0	0	0 (1st)
0	1	2 (2nd)
1	0	4 (3rd)
1	1	6 (4th)

Installation Instructions
Block I/O
Cat. No. 1791-16BC Series B

1747-SN Rack Number	1771-SN Rack Number	PLC-2 Rack Number	PLC-5 Rack Number	PLC-5/250 Rack Number	PLC-3 Rack Number	SW1 Switch Position					
						8	7	6	5	4	3
Rack 0	Rack 1	Rack 1	Not Valid	Rack 0	Rack 0	0	0	0	0	0	0
Rack 1	Rack 2	Rack 2	Rack 1	Rack 1	Rack 1	0	0	0	0	0	1
Rack 2	Rack 3	Rack 3	Rack 2	Rack 2	Rack 2	0	0	0	0	1	0
Rack 3	Rack 4	Rack 4	Rack 3	Rack 3	Rack 3	0	0	0	0	1	1
	Rack 5	Rack 5	Rack 4	Rack 4	Rack 4	0	0	0	1	0	0
	Rack 6	Rack 6	Rack 5	Rack 5	Rack 5	0	0	0	1	0	1
	Rack 7	Rack 7	Rack 6	Rack 6	Rack 6	0	0	0	1	1	0
			Rack 7	Rack 7	Rack 7	0	0	0	1	1	1
			Rack 10	Rack 10	Rack 10	0	0	1	0	0	0
			Rack 11	Rack 11	Rack 11	0	0	1	0	0	1
			Rack 12	Rack 12	Rack 12	0	0	1	0	1	0
			Rack 13	Rack 13	Rack 13	0	0	1	0	1	1
			Rack 14	Rack 14	Rack 14	0	0	1	1	0	0
			Rack 15	Rack 15	Rack 15	0	0	1	1	0	1
			Rack 16	Rack 16	Rack 16	0	0	1	1	1	0
			Rack 17	Rack 17	Rack 17	0	0	1	1	1	1
			Rack 20	Rack 20	Rack 20	0	1	0	0	0	0
			Rack 21	Rack 21	Rack 21	0	1	0	0	0	1
			Rack 22	Rack 22	Rack 22	0	1	0	0	1	0
			Rack 23	Rack 23	Rack 23	0	1	0	0	1	1
			Rack 24	Rack 24	Rack 24	0	1	0	1	0	0
			Rack 25	Rack 25	Rack 25	0	1	0	1	0	1
			Rack 26	Rack 26	Rack 26	0	1	0	1	1	0
			Rack 27	Rack 27	Rack 27	0	1	0	1	1	1
			Rack 30	Rack 30	Rack 30	0	1	1	0	0	0
			Rack 31	Rack 31	Rack 31	0	1	1	0	0	1
			Rack 32	Rack 32	Rack 32	0	1	1	0	1	0
			Rack 33	Rack 33	Rack 33	0	1	1	0	1	1
			Rack 34	Rack 34	Rack 34	0	1	1	1	0	0
			Rack 35	Rack 35	Rack 35	0	1	1	1	0	1
			Rack 36	Rack 36	Rack 36	0	1	1	1	1	0
			Rack 37	Rack 37	Rack 37	0	1	1	1	1	1
			Rack 40	Rack 40	Rack 40	1	0	0	0	0	0
			Rack 41	Rack 41	Rack 41	1	0	0	0	0	1
			Rack 42	Rack 42	Rack 42	1	0	0	0	1	0
			Rack 43	Rack 43	Rack 43	1	0	0	0	1	1
			Rack 44	Rack 44	Rack 44	1	0	0	1	0	0
			Rack 45	Rack 45	Rack 45	1	0	0	1	0	1
			Rack 46	Rack 46	Rack 46	1	0	0	1	1	0
			Rack 47	Rack 47	Rack 47	1	0	0	1	1	1
			Rack 50	Rack 50	Rack 50	1	0	1	0	0	0

Installation Instructions

Block I/O

Cat. No. 1791-16BC Series B

1747-SN Rack Number	1771-SN Rack Number	PLC-2 Rack Number	PLC-5 Rack Number	PLC-5/250 Rack Number	PLC-3 Rack Number	SW1 Switch Position					
						8	7	6	5	4	3
					Rack 51	1	0	1	0	0	1
					Rack 52	1	0	1	0	1	0
					Rack 53	1	0	1	0	1	1
					Rack 54	1	0	1	1	0	0
					Rack 55	1	0	1	1	0	1
					Rack 56	1	0	1	1	1	0
					Rack 57	1	0	1	1	1	1
					Rack 60	1	1	0	0	0	0
					Rack 61	1	1	0	0	0	1
					Rack 62	1	1	0	0	1	0
					Rack 63	1	1	0	0	1	1
					Rack 64	1	1	0	1	0	0
					Rack 65	1	1	0	1	0	1
					Rack 66	1	1	0	1	1	0
					Rack 67	1	1	0	1	1	1
					Rack 70	1	1	1	0	0	0
					Rack 71	1	1	1	0	0	1
					Rack 72	1	1	1	0	1	0
					Rack 73	1	1	1	0	1	1
					Rack 74	1	1	1	1	0	0
					Rack 75	1	1	1	1	0	1
					Rack 76	1	1	1	1	1	0
					Not Valid	1	1	1	1	1	1

Rack address 77 is an illegal configuration.

PLC-5/11 processors can scan rack 03.

PLC-5/15 and PLC-5/20 processors can scan racks 01–03.

PLC-5/25 and PLC-5/30 processors can scan racks 01–07.

PLC-5/40 and PLC-5/40L processors can scan racks 01–17.

PLC-5/60 and PLC-5/60L processors can scan racks 01–27.

PLC-5/250 processors can scan racks 00–37.

The SLC 500 controllers communicate with the block I/O using an I/O Scanner module (cat. no. 1747-SN series A). Refer to the user manual for the 1747-SN/A Scanner module for more information.

Important: This block I/O module is **not** compatible with the **1747-DSN** Distributed I/O Scanner module.

Termination Resistor

A termination resistor must be installed on the last block in a series. Connect the resistor as shown in Figure 7.

Figure 7
Installing the Termination Resistor

Connect termination resistor across terminals 6 (BLU) and 8 (CLR).

150 ohm – 57.6K and 115.2K bits/s
 82 ohm – 230.4K bits/s

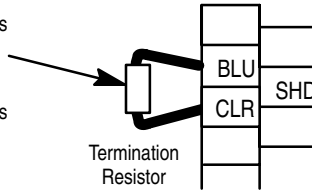

10835-I



ATTENTION: Devices that are operating at 230.4K bits/s must have 82 ohm terminators in place for proper operation.

Indicators

PLC

COMM				IN	OUT
				G	G
<input type="checkbox"/>	<input type="checkbox"/>	<input type="checkbox"/>	<input type="checkbox"/>	00	10
<input type="checkbox"/>	<input type="checkbox"/>	<input type="checkbox"/>	<input type="checkbox"/>	01	11
<input type="checkbox"/>	<input type="checkbox"/>	<input type="checkbox"/>	<input type="checkbox"/>	02	12
<input type="checkbox"/>	<input type="checkbox"/>	<input type="checkbox"/>	<input type="checkbox"/>	03	13
<input type="checkbox"/>	<input type="checkbox"/>	<input type="checkbox"/>	<input type="checkbox"/>	04	14
<input type="checkbox"/>	<input type="checkbox"/>	<input type="checkbox"/>	<input type="checkbox"/>	05	15
<input type="checkbox"/>	<input type="checkbox"/>	<input type="checkbox"/>	<input type="checkbox"/>	06	16
<input type="checkbox"/>	<input type="checkbox"/>	<input type="checkbox"/>	<input type="checkbox"/>	07	17
STATUS					

SLC

COMM				IN	OUT
				G	G
<input type="checkbox"/>	<input type="checkbox"/>	<input type="checkbox"/>	<input type="checkbox"/>	00	08
<input type="checkbox"/>	<input type="checkbox"/>	<input type="checkbox"/>	<input type="checkbox"/>	01	09
<input type="checkbox"/>	<input type="checkbox"/>	<input type="checkbox"/>	<input type="checkbox"/>	02	10
<input type="checkbox"/>	<input type="checkbox"/>	<input type="checkbox"/>	<input type="checkbox"/>	03	11
<input type="checkbox"/>	<input type="checkbox"/>	<input type="checkbox"/>	<input type="checkbox"/>	04	12
<input type="checkbox"/>	<input type="checkbox"/>	<input type="checkbox"/>	<input type="checkbox"/>	05	13
<input type="checkbox"/>	<input type="checkbox"/>	<input type="checkbox"/>	<input type="checkbox"/>	06	14
<input type="checkbox"/>	<input type="checkbox"/>	<input type="checkbox"/>	<input type="checkbox"/>	07	15
STATUS					

Indicator	Description
COMM OFF ON Flashing	Communication not established Communication established Processor in Program mode
STATUS OFF ON Flashing	Normal Error (hardware or software), block power low COMM FAIL – communication cable disconnected, 100ms between valid frames, no more than 255 valid frames between valid frames addressed to block, 20ms idle time exceeded.

COMM and STATUS will alternately flash when processor restart lockout is selected, a fault has occurred and the processor is communicating with the block.

Installation Instructions

Block I/O

Cat. No. 1791-16BC Series B

Fusing

The block I/O module is internally fused to protect the module. No external power fusing is required.

The outputs of the block I/O modules are not fused. Fusing of outputs is recommended. If desired to fuse an output, you must provide external fusing.

Table C
Recommended Fuses

Type of Circuit	Part Number ¹	Size	Rating in Amps	Maximum Surge Current ² (repeatable every 2s)
dc	Littelfuse 322 1.25	0.25 in. x 1.25 in.	1.25A	2.25A for 50ms
	SAN-O MQ4-800	5mm x 20mm	800mA ³	2.0A for 50ms

¹ **Note:** Do not substitute another fuse for those listed.

² The recommended fuses will withstand surges of the above listed currents for the time specified.

³ Current must be limited to 650mA when using this fuse.

Block I/O modules are derated linearly above 30°C up to and including 60°C.

Table D
Output Ratings and Non-fused Surge Currents

Catalog Number	Voltage	Mounting	Max. Output Rating:		Maximum Surge Current ¹ (repeatable every 2s)
			@ 30°C	@ 60°C	
1791-16BC/B	24V dc	Vertical	1A	500mA	3A for 50ms
		Horizontal	500mA	250mA	

¹ These surge ratings are for non-fused outputs only.

1791-16BC Specifications

Input Specifications

Inputs per Block		16 – 2 groups of 8
On-state Voltage Range		10–30V dc
On-state Current	Maximum Minimum	11.0mA @ 30V 2.5mA @ 10V
Off-state Voltage	Maximum	5V dc
Off-state Current	Minimum	1.5mA
Input Impedance	Maximum	3.4K ohms
Input Signal Delay	Fast Slow	1.0ms on; 5.0ms off (maximum) 1.0ms on; 18.0ms off (maximum)

Output Specifications

Outputs per Block		16 – 2 groups of 8
Output Voltage Range		10–30V dc
Output Current Rating	Vertical Mtg. Horizontal Mtg.	500mA @ 60°C, 1A @ 30°C 250mA @ 60°C, 500mA @ 30°C
Surge Current		3A for 50ms each, repeatable every 2 sec.
Minimum On-state Current		1mA per output
Maximum On-state Voltage Drop		1.0V @ rated current
Off-state Leakage Current (maximum)		0.5mA
Output Signal Delay		0.5ms on; 1.0ms off (maximum)

Specifications continued on next page

Installation Instructions

Block I/O

Cat. No. 1791-16BC Series B

1791-16BC Specifications

General Specifications

External Power (internally protected - no external fuse required)	Voltage	19.2–30V dc
	Current	300mA
Dimensions	Inches	6.95H X 4.35W X 3.85D
	Millimeters	176.5H X 110.5W X 98D
Isolation	Power supply to RIO	500V ac
	I/O Group-to-Group	500V ac
	I/O Group-to-Logic	500V ac
Power Dissipation	Maximum	17.8 Watts
Thermal Dissipation	Maximum	60.6 BTU/hr
Environmental Conditions	Operational Temperature	0 to 60°C (32 to 140°F)
	Storage Temperature	–40 to 85°C (–40 to 185°F)
	Relative Humidity	5 to 95% noncondensing
Conductors	Wire Size	14 gauge (2mm ²) stranded maximum 3/64 inch insulation maximum
	Category	2 ¹

¹ You use this conductor category information for planning conductor routing as described in the system level installation manual.



ALLEN-BRADLEY
A ROCKWELL INTERNATIONAL COMPANY

WORLD HEADQUARTERS
Allen-Bradley
1201 South Second Street
Milwaukee, WI 53204 USA
Tel: (414) 382-2000
Telex: 43 11 016
FAX: (414) 382-4444

With offices in major cities worldwide _____