

WEB-600

MODELS: WEB-600, WEB-600-O, WEB-600-US,
WEB-600-O-US

SPECIFICATION DATA



FEATURES

- Supports open and legacy protocols.
- Web User Interface (standard) serves rich presentation and live data to a browser.
- Run stand-alone control, energy management, and multi-protocol integration.
- Standard and optional communications boards.
- Can be expanded with optional 16 and 34 point I/O Modules.
- Small compact design is easy to install and supports multiple power options.
- Embedded IBM® Power PC Platform.

GENERAL

The WEB-600 is a compact, embedded controller/server platform. It combines integrated control, supervision, data logging, alarming, scheduling and network management functions with Internet connectivity and web serving capabilities in a small, compact platform. The WEB-600 makes it possible to control and manage external devices over the Internet and present real time information to users in web-based graphical views.

The WEB-600 is a member of the WEBs-AX™ suite of Java®-based controller/server products, software applications and tools, which are designed to integrate a variety of devices and protocols into unified, distributed systems. WEBs-AX™ products are powered by the revolutionary NiagaraAX Framework®, the industry's first software technology designed to integrate diverse systems and devices into a seamless system. NiagaraAX supports a wide range of protocols including LONWORKS®, BACnet®, Modbus®, and Internet standards. The NiagaraAX Framework® also includes integrated network management tools to support the design, configuration, installation and maintenance of interoperable networks.

APPLICATION

The WEB-600 is ideal for smaller facilities, remote sites, and for distributing control and monitoring throughout large facilities. Optional I/O modules can be plugged in for applications where local control is required. The WEB-600 controller also supports a wide range of field busses for connection to remote I/O and stand-alone controllers. In small facility applications, the WEB-600 controller is all you need for a complete system.

The WEB-600 controller serves data and rich graphical displays to a standard web browser via an Ethernet LAN or remotely over the Internet, or dial-up modem. In larger facilities, multi-building applications and large-scale control system integrations, WEBStation-AX™ software can be used to aggregate information (real-time data, history, alarms, etc.) from large numbers of WEBs-AX™ controllers into a single unified application. The WEBStation-AX™ Supervisor can manage global control functions, support data passing over multiple networks, connect to enterprise level softwa



BTL is a registered trademark of BTL. BTL does not warrant, approve or endorse any products or services of BTL, its affiliates, or any other third party. BTL is not responsible for any damage or loss resulting from the use of BTL products. BTL is a registered member of the BTL Association.



74-4067-02

applications, and host multiple, simultaneous client workstations connected over the local network, the Internet, or dial-up modem.

Table 1.

Part Number	Description
WEB-600	Based unit including two Ethernet ports, one RS-232 port, one RS-485 port, one USB port, Web User Interface, Niagara ^{AX} Connectivity, and oBix™ driver included.
WEB-600-O	WEB-600 with open license (NiCS has accept.wb.in="**")
WEB-600-US	WEB-600 controller manufactured in the USA.
WEB-600-O-US	WEB-600 controller with open license manufactured in the USA.

SPECIFICATIONS

Model: WEB-600 Controller: Base Unit including two Ethernet ports, one RS-232 port, one RS-485 port, one USB port, Web User Interface, Niagara^{AX} Connectivity, and oBix driver.

Platform: IBM® PowerPC® 440 524 MHz processor. 128 MB DDR RAM & 128 MB Serial Flash. Optional 256 MB DDR RAM.

Battery Backup - 5 minutes typical - shutdown begins within 10 seconds.

Real-time clock - 3 month backup maximum via battery.

Communications: 2 Ethernet Ports - 10/100 Mbps (RJ-45 Connectors).

1 RS-232 Port (9 pin D-shell connector).

1 RS-485 non isolated port (3 Screw Connector on base board).

256 MB Memory Upgrade Option: Memory upgrade option (NPM-256) increases memory to 256 MB DDR.

Operating System: QNX® RTOS, IBM J9™ JVM® Java Virtual Machine, Niagara^{AX} 3.1 or later.

Chassis: Construction: Plastic, din rail or screw mount chassis, plastic cover.

Cooling: Internal air convection.

Dimensions: 6.3 in. (160 mm) W x 4.8 in. (122 mm) H (including connectors) x 2.4 in. (61 mm) D.

Temperature Ratings: Operating temperature range: 32° to 122° F (0° to 50° C).

Storage Temperature range: 32° to 158° F (0° to 70° C).

Humidity Rating: 5% to 95% RH, non-condensing.

Approvals: RoHS, BTL (with optional BACnet driver), UL 916, C-UL listed to Canadian Standards Association (CSA) C22.2 No. 205-M1983 "Signal Equipment", CE, FCC part 15 Class A, C-tick (Australia).

Optional Communications Cards: Manufactured in the US

Table 2.

Part Number	Description
DR-LONFT10-AX	Optional 78 Kbps FTT10 A LON® Adapter and LonWorks communication driver. (card and driver bundle).
NBP-LON	Optional 78 kbps FTT10 LON adapter (card only).
NPB-RS232	Optional RS-232 port adapter with 9 pin D-shell connector.
NPB-2X-RS485	Optional dual port RS-485 adapter, electrically isolated.
NPB-MDM	Optional Auto-dial / Auto-answer 56 KBPS modem; consumes one option card slot; cannot be used if NPB-GPRS-H modem is selected.
NPB-GPRS-H	Optional GPRS Modem communications card with SIM card for connection via Wyleless network; Wyleless is the only approved service provider for the continental US, consumes one option card slot.

Power Supply Options:

Table 3.

Part Number	Description
NPB-PWR-H	Optional: 24 Vac/dc power supply module, Din Rail mounted. Manufactured in the US.
NPB-PWR-UN-H	Optional universal voltage input power supply module, Din Rail mounted. Input voltage is 90 - 263 Volts AC, 50/60 Hz, auto adjusting.
NPB-WPM-US	Optional Wall Power Module. Input 120 Vac, 50-60 Hz. US wall plug power supply.

Optional I/O Modules: Table 4 lists the I/O models that can be connected to the WEB-600. Optionally, IO-16-REM-H can be connected; details can be found in the data sheet 74-5082.

Table 4.

Feature	IO-16 WEB-IO-16	IO-16-US	IO-34 WEB-IO-34	IO-34-US
Manufactured in	China	USA	China	USA
Universal Inputs	8		16	
Relay Outputs	4		10	
Analog Outputs	4		8	
Dimensions (in inches)	3.2W x 4.8H x 2.4D		6.3W x 4.8H x 2.4D	
Dimensions (in mm)	82W x 122H x 61D		160W x 122H x 61D	
Max per WEB-600 controller	4 / 2*		1	

*4 or 2 in combination with IO-34/IO-34-US.

I/O Specifications - All Modules: Connection to WEB-600 Controller is via a single multi-pin plug.

Removable screw terminals (0.2 in. [5.08 mm] centers) for all inputs and outputs.

Universal Input types supported:

Type 3 (10K) Thermistors; Thermistor Sensor Range -10° to +240° F (23° to +116° C). Input accuracy is in the range of +/-1% of span. Others may be supported by entering custom non-linear curve interpolation points for each unique non-linear input.

0 to 10 volt; accuracy is +/- 2% of span, without user calibration; uses an external resistor for current input (four provided, mounted by installer on terminal connections) 4/20 mA current loop; accuracy is +/- 2% of span, without user calibration; self-powered or board-powered sensors accepted.

Dry contact; V open circuit, 300-uA short-circuit current. Pulsing dry contact at a rate of up to 20 Hz; 50% duty cycle.

Digital Outputs (4 ea.) Pilot Duty.

Form A relay contacts suitable for on/off control only; floating control not supported.

Maximum voltage - 30V DC or AC.

1/2 Amp maximum current rating.

Analog Outputs:

0 -10 Volt DC.

Minimum load supported per output is 2500 ohms minimum or 4 mA drain maximum.

WEBS-AX™ System Integration

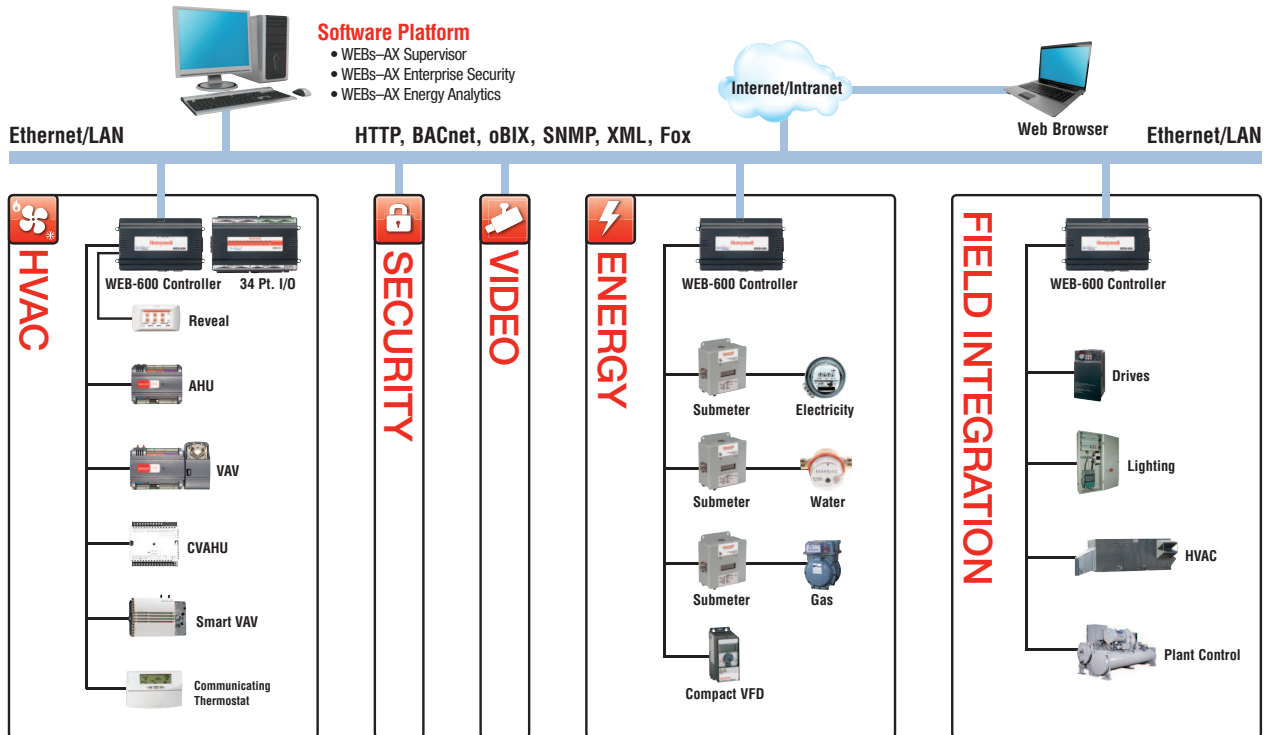

WEB-600ARCH PR
November 2010

WEB-600

BACnet® is a registered trademark of the American Society of Heating, Refrigerating, and Air-Conditioning Engineers, Inc. (ASHRAE).

IBM® and PowerPC® are registered trademarks and J9™ is a trademark of International Business Machines Corporation.

JVM® and JAVA® are registered trademark of Sun Microsystems, Inc.

LON® and LONWORKS® are registered trademarks of Echelon Corporation.

Modbus® is a registered trademark of Schneider Automation, Inc.

NiagaraAX™ and the Niagara logo are trademarks and Niagara Framework® is a registered trademark of Tridium, Inc.

oBix™ is a trademark of Clinical Computer Systems, Inc.

QNX® is a registered trademark of QNX Software Systems, Ltd.

Tradeline™, WEBs-AX™ and WEBStation-AX™ are trademarks of Honeywell International, Inc.

Automation and Control Solutions

Honeywell International Inc.
1985 Douglas Drive North
Golden Valley, MN 55422

Honeywell Limited-Honeywell Limitée
35 Dynamic Drive
Toronto, Ontario M1V 4Z9
customer.honeywell.com

® U.S. Registered Trademark
© 2010 Honeywell International Inc.
74-4067—02 T.D. Rev. 11-10
Printed in U.S.A.

Honeywell