

# Modicon

## S908 Remote I/O Cable

### System Planning and Installation Guide

07/2017

---

The information provided in this documentation contains general descriptions and/or technical characteristics of the performance of the products contained herein. This documentation is not intended as a substitute for and is not to be used for determining suitability or reliability of these products for specific user applications. It is the duty of any such user or integrator to perform the appropriate and complete risk analysis, evaluation and testing of the products with respect to the relevant specific application or use thereof. Neither Schneider Electric nor any of its affiliates or subsidiaries shall be responsible or liable for misuse of the information contained herein. If you have any suggestions for improvements or amendments or have found errors in this publication, please notify us.

You agree not to reproduce, other than for your own personal, noncommercial use, all or part of this document on any medium whatsoever without permission of Schneider Electric, given in writing. You also agree not to establish any hypertext links to this document or its content. Schneider Electric does not grant any right or license for the personal and noncommercial use of the document or its content, except for a non-exclusive license to consult it on an "as is" basis, at your own risk. All other rights are reserved.

All pertinent state, regional, and local safety regulations must be observed when installing and using this product. For reasons of safety and to help ensure compliance with documented system data, only the manufacturer should perform repairs to components.

When devices are used for applications with technical safety requirements, the relevant instructions must be followed.

Failure to use Schneider Electric software or approved software with our hardware products may result in injury, harm, or improper operating results.

Failure to observe this information can result in injury or equipment damage.

© 2017 Schneider Electric. All Rights Reserved.

---

# Table of Contents

---



	<b>Safety Information</b> . . . . .	7
	<b>About the Book</b> . . . . .	9
<b>Chapter 1</b>	<b>Remote I/O Networks—A Communications Overview</b> . .	11
	RIO Network Communications . . . . .	12
	Processing Nodes on the RIO Network . . . . .	13
	RIO Drop Addressing . . . . .	15
	RIO Network Cable System . . . . .	16
	RIO Network Node Part Number Summary . . . . .	18
<b>Chapter 2</b>	<b>Planning and Designing an RIO Cable System</b> . . . . .	19
	Linear Cable Topologies . . . . .	20
	Hot Standby Cable Topologies . . . . .	24
	Trunk Splitter Use . . . . .	28
	Illegal Coaxial Cable Topologies . . . . .	30
	Using Fiber Optics in an RIO System . . . . .	33
	RIO System Design . . . . .	40
	Choosing Coaxial Cables for an RIO Network . . . . .	42
	Coaxial Cable Characteristics . . . . .	44
	Electrical Characteristics of Coaxial Media Components . . . . .	45
	EMI/RFI Considerations in a Coaxial Cable Routing Plan . . . . .	47
	Tap Connections and Locations . . . . .	48
	Grounding and Surge Suppression . . . . .	50
	Terminating a Coaxial Cable System . . . . .	52
	Designing a Coaxial Cable System to an Attenuation Limit . . . . .	53
	Attenuation Considerations in an Optical Path . . . . .	57
	Maximum Number of 490NRP954 Repeaters and Jitter Considerations . . . . .	59
	Planning RIO Drops . . . . .	61
<b>Chapter 3</b>	<b>RIO Network Hardware Components</b> . . . . .	67
	RG-6 Cable . . . . .	68
	RG-11 Cable . . . . .	69
	Semirigid Cable . . . . .	70
	Selecting Fiber Optic Cable . . . . .	71
	Hardware Overview . . . . .	72
	Tap Specifications . . . . .	74
	Splitter Specifications . . . . .	76
	F Connectors for Coaxial Cables . . . . .	78

---

	F Adapters for Semirigid Cable .....	80
	BNC Connectors and Adapters .....	81
	Network Terminators .....	83
	Self-terminating F Adapter Options .....	85
	Ground Blocks .....	87
	Surge Suppressors .....	88
	140NRP95400 and 140NRP95401C Fiber Optic Repeater Modules ..	90
	490NRP954 Fiber Optic Repeater .....	95
	Recommended Materials for Multimode Fiber Optic Links .....	99
<b>Chapter 4</b>	<b>Installing an RIO Network. ....</b>	<b>101</b>
	Installation Overview .....	102
	RG-6 Cable Connections .....	103
	RG-6 Cable Installation Tool .....	104
	Preparing RG-6 Cable for a Connector .....	106
	Installing F Connectors on Quad Shield RG-6 Cable .....	108
	Installing BNC or Self-terminating F Connectors on RG-6 Cable ....	111
	RG-11 Cable Connections .....	113
	The RG-11 Installation Tool .....	114
	Installing F Connectors on RG-11 Cable .....	115
	Semirigid Cable Connections .....	119
	Semirigid Cable Installation Tools .....	120
	Preparing a Semirigid Cable for a Connector .....	121
	Installing F Connectors on Semirigid Cable .....	122
	Semirigid Trunk Cable Tap Port Connections .....	123
	Providing Line Termination on the Drop Cable .....	124
	Connecting/Disconnecting a Drop Cable at a Tap .....	126
	Installing 140NRP95400 and 140NRP95401C Fiber Optic Repeater Modules .....	128
	Installing 490NRP954 Fiber Optic Repeaters .....	133
	Terminating the Trunk Cable .....	137
	Installing the Ground Point. ....	138
<b>Chapter 5</b>	<b>Testing and Maintaining an RIO Network. ....</b>	<b>139</b>
	Maintenance and Testing Requirements .....	140
	Coax RIO System Network Integrity .....	142
	Problem Sources on an RIO Network .....	144
	On-line and Off-line Error Isolation .....	146
	Troubleshooting 140NRP95400 and 140NRP95401C Fiber Optic Repeater Modules .....	147
	Troubleshooting 490NRP954 Fiber Optic Repeaters .....	149

---

<b>Appendices</b>	.....	<b>151</b>
<b>Appendix A</b>	<b>RIO Cable Material Suppliers</b> .....	<b>153</b>
	RIO Cable Material Suppliers .....	<b>153</b>
<b>Glossary</b>	.....	<b>155</b>
<b>Index</b>	.....	<b>165</b>



---

# Safety Information

---



## Important Information

### NOTICE

Read these instructions carefully, and look at the equipment to become familiar with the device before trying to install, operate, service, or maintain it. The following special messages may appear throughout this documentation or on the equipment to warn of potential hazards or to call attention to information that clarifies or simplifies a procedure.



The addition of this symbol to a “Danger” or “Warning” safety label indicates that an electrical hazard exists which will result in personal injury if the instructions are not followed.



This is the safety alert symbol. It is used to alert you to potential personal injury hazards. Obey all safety messages that follow this symbol to avoid possible injury or death.

## **DANGER**

**DANGER** indicates a hazardous situation which, if not avoided, **will result in** death or serious injury.

## **WARNING**

**WARNING** indicates a hazardous situation which, if not avoided, **could result in** death or serious injury.

## **CAUTION**

**CAUTION** indicates a hazardous situation which, if not avoided, **could result in** minor or moderate injury.

## **NOTICE**

**NOTICE** is used to address practices not related to physical injury.

---

## PLEASE NOTE

Electrical equipment should be installed, operated, serviced, and maintained only by qualified personnel. No responsibility is assumed by Schneider Electric for any consequences arising out of the use of this material.

A qualified person is one who has skills and knowledge related to the construction and operation of electrical equipment and its installation, and has received safety training to recognize and avoid the hazards involved.



---

# About the Book

---



## At a Glance

### Document Scope

This manual is intended for the design engineer, cable system installer and network manager involved with a Modicon S908 Remote I/O (RIO) network. The manual describes:

- Design, installation, test, and maintenance procedures for the S908 RIO network.
- Required media hardware – for example cables, taps, connectors, fiber optic options, tools – and approved optional hardware for special situations and environments.
- S908 RIO communication processing devices used with the Quantum Automation Series CPUs and the 984 family of PLCs.
- Recommended installation and maintenance tests for the S908 RIO network.

### Validity Note

The technical characteristics of the devices described in this document also appear online. To access this information online:

Step	Action
1	Go to the Schneider Electric home page <a href="http://www.schneider-electric.com">www.schneider-electric.com</a> .
2	In the <b>Search</b> box type the reference of a product or the name of a product range. <ul style="list-style-type: none"><li>• Do not include blank spaces in the reference or product range.</li><li>• To get information on grouping similar modules, use asterisks (*).</li></ul>
3	If you entered a reference, go to the <b>Product Datasheets</b> search results and click on the reference that interests you. If you entered the name of a product range, go to the <b>Product Ranges</b> search results and click on the product range that interests you.
4	If more than one reference appears in the <b>Products</b> search results, click on the reference that interests you.
5	Depending on the size of your screen, you may need to scroll down to see the data sheet.
6	To save or print a data sheet as a .pdf file, click <b>Download XXX product datasheet</b> .

The characteristics that are presented in this manual should be the same as those characteristics that appear online. In line with our policy of constant improvement, we may revise content over time to improve clarity and accuracy. If you see a difference between the manual and online information, use the online information as your reference.



---

# Chapter 1

## Remote I/O Networks—A Communications Overview

---

### Overview

This chapter provides an overview of remote I/O (RIO) networks.

### What Is in This Chapter?

This chapter contains the following topics:

Topic	Page
RIO Network Communications	12
Processing Nodes on the RIO Network	13
RIO Drop Addressing	15
RIO Network Cable System	16
RIO Network Node Part Number Summary	18

## RIO Network Communications

### Overview

Modicon's RIO network is a high speed (1.544 Mbit/s) local area network (LAN) that uses commercially available coaxial cable and CATV media technology. RIO supports:

- Discrete and register data to input and output module communications
- ASCII message transmissions to and from certain RIO drop adapters

### Data Transfer Consistency

PLCs service their drop adapters at the beginning and end of logic segments when Ladder programming is used, or, for IEC, before and after all sections have been executed. Most data transfers between head and remote drop take less than 1 ms. A CRC 16 message frame check assures that RIO messages will arrive reliably and completely error-checked at the proper destination node.

### How Messages are Transmitted

A message initiated by the RIO head processor travels along the network's cable system and is received by all RIO adapters. The RIO adapter with the address specified in the message can then transmit a response message back to the RIO head within a specific time period. If the drop adapter does not respond, the same message is sent again. The process of resending the message after no response is called a *retry*.

If the adapter does not respond to several retries, the drop is declared dead. On each successive scan of the PLC, the RIO head attempts to re-establish communications with the adapter—only one attempt per scan will be made to communicate with a dead drop until the adapter is successfully brought back up.

### Predictable Speeds for Time-critical Applications

As a high speed LAN, RIO must support applications that are very time-critical. In this respect, RIO has several advantages over other proprietary PLC communication methods. These advantages include:

- HDLC protocol implementation makes the RIO data transfer speed very predictable
- The PLC services each node using a consistent communications method—the I/O drops are always updated in a determinate time period that can be calculated based on the number of segments or sections in the user logic program
- Only one node transmits at a given time, so message collisions do not occur—each node is able to transmit on the network in a determinate time period
- RIO has high data integrity due to the frame check sequence and error checking at the physical protocol layer

## Processing Nodes on the RIO Network

### Overview

The RIO network supports communications between a PLC and one or more drops of I/O modules dispersed throughout your local area—e.g., your manufacturing or processing facility. All messages on the RIO network are initiated by a master node called the *RIO head or processor*. All other nodes on the network communicate with the RIO head via *RIO adapters* located at the drops. The network is proprietary, and Schneider Electric processing nodes must be used throughout the RIO network.

### RIO Processors

RIO is fundamentally a single-master network, and the RIO processor is the master node. The RIO processor is located at the PLC at the head-end of the RIO network. Depending on the type of PLC you are using, the RIO processor can be implemented in hardware as an option module that mounts beside the PLC or as a board built into the PLC.

PLC Type	RIO Processor	Dynamic Range	Max. RIO Drops
984A	S908 chassis module	35 dB	32
984B	S908 chassis module	35 dB	32
984X	On the S929 Processor	35 dB	6
AT-984	On host-based PLC card	32 dB	6
MC-984	On host-based PLC card	32 dB	6
Q-984	On host-based PLC card	32 dB	6
984-485E/K	S908 slot mount module	35 dB	6
984-685E	S908 slot mount module with AS-E908-016 Executive	35 dB	15
	S908 slot mount module with AS-E908-131 Executive	35 dB	31
984-785E/K/D	S908 slot mount module with AS-E908-016 Executive	35 dB	15
	S908 slot mount module with AS-E908-131 Executive	35 dB	31
Quantum	140CRP931 or 140CRP932 Quantum module	35 dB	31

## RIO Adapters

An adapter module resides at each remote drop on the RIO network. The type of adapter used depends on:

- the type of RIO processor at the head-end of the network
- the series of I/O modules at the drop
- whether or not ASCII devices are being supported at the drop
- whether the drop adapter will support one or two RIO cables

Drop Adapter	Head Processor	I/O at the Drop	ASCII Ports	RIO Cable Ports
140CRA93100	140CRP93100	Quantum	N/A	1
140CRA93200	140CRP93200	Quantum	N/A	2
AS-J890-001/101	S908 or CRP93X	800	0	1
AS-J890-002/102	S908 or CRP93X	800	0	2
AS-J892-001/101	S908 or CRP93X	800	2	1
AS-J892-002/102	S908 or CRP93X	800	2	2
AS-P890-000	S908 or CRP93X	800	0	1
ASP890300	S908 or CRP93X	800	2	2
AS-P892-000	S908 or CRP93X	800	2	1

## Field Adapter Kits

Field adapter kits are also available to convert the P451 and most P453 adapters to the S908 RIO protocol. This conversion allows the Quantum CPUs, the 984 controllers, and the host-based CPUs to support installed drops of 200 Series I/O.

Kit	New RIO Adapter	RIO Ports	ASCII Ports	Power Supply
AS-J290-010	AS-P453-581	1	0	50 Hz
	AS-P453-681	1	0	60 Hz
	AS-P453-582	1	2	50 Hz
	AS-P453-682	1	2	60 Hz
AS-J290-020	AS-P453-591	2	0	50 Hz
	AS-P453-691	2	0	60 Hz
	AS-P453-592	2	2	50 Hz
	AS-P453-692	2	2	60 Hz
AS-J291-010	AS-P451-581	1	0	50 Hz
	AS-P451-681	1	0	60 Hz

## RIO Drop Addressing

### Overview

Each RIO drop adapter on the network must be assigned a unique address number. The RIO processor uses this *drop address* to send I/O module data or ASCII message data to the proper adapter. The physical location of an adapter on the network has no bearing on its address or on the data throughput, making the RIO network a true bus architecture.

### Setting Drop Addresses

RIO drop adapters have switches on them that are used to set the unique RIO drop addresses and ASCII port addresses (if ASCII devices are supported at the drops). DIP switches are used on the 984 type adapters, and rotary switches are used on Quantum adapters. Consult the hardware documentation for location of the switches and appropriate settings.

## RIO Network Cable System

### Overview

The RIO processor at the controller head-end is connected to an adapter at each of the remote drops via a network cable system.

### Trunk Cable

Starting at the RIO processor and running the entire length of the network are one (linear) or two (dual or redundant) *trunk* cable(s). Taps are installed along the length of the trunk cable(s), and a drop cable is run from a tap to a drop adapter. The trunk cable may be an approved flexible or semirigid coaxial type. See *RIO Network Hardware Components*, [page 67](#) for more details.

### Taps

The taps connect the drop adapter at each drop to the trunk cable via a drop cable, providing each adapter with a portion of the signal that is on the trunk. The taps also isolate each drop adapter from all other drop adapters on the network so that they won't interfere with each other.

### Drop Cable

Extending from a tap to an adapter is a drop cable. The drop cable connects to the tap with an F connector, and it connects to the adapter with either an F connector or a BNC connector, depending on the type of RIO adapter at the drop (see *Planning RIO Drops*, [page 61](#)). The drop cable may be an approved coaxial type, as specified in *RIO Network Hardware Components*, [page 67](#).

### Splitters

Splitters are used to create a branch in the network cable trunk. They provide isolation between the branches and allow the cable to be laid out in two directions. One trunk splitter is allowed in a network. Hot Standby systems are allowed a second splitter to connect the two RIO heads.

### Terminating the Cable System

A proper impedance match is maintained across the network with 75  $\Omega$  terminators. You must install a 75  $\Omega$  terminator:

- in the unused trunk port of the last tap on the network to terminate the trunk cable
- in any open drop cable ports on taps that have been installed for future system expansion
- in-line on cables running from the primary and standby controllers to the splitter in a Hot Standby system; this allows you to disconnect one of the two Hot Standby controllers while the other one maintains primary control



Terminators are present inside most drop adapters to automatically terminate each drop connection—the exceptions are some older J890/J892 Adapters and the 410 and 3240 Motion Control products:

<b>RIO Adapters that Do Not Have Internal Termination</b>	
<b>RIO Drop Adapters</b>	
AS-J890-001	AS-J892-001
AS-J890-002	AS-J890-002
<b>410 Motion Controllers</b>	
110-230	110-231
110-232	110-233
<b>3240 Motion Controllers</b>	
100-265-815	
100-265-816	
100-265-825	

The devices listed above require an in-line terminator (part number 60-0513-000) installed in the drop cable.

**NOTE:** The J890/J892-10x Adapters contain internal termination.

When a drop cable without in-line termination gets disconnected from an adapter while the network is running, the possibility of network errors and data transfer delays is introduced. When internally terminated adapters are installed, you may want to consider designing mechanical self-termination into your drop cables, particularly if a time-critical application is being run on the network. For more details on this and other aspects of cable system termination, see *Tap Connections and Locations*, [page 48](#).

## RIO Network Node Part Number Summary

### RIO Devices

The following table shows RIO device types.

RIO Device Type		One RIO Port	Two RIO Ports
Head Processor	in a 16K 984A chassis (standard)	Px-984A-816*	
	in a 32K 984A chassis (standard)	Px-984A-832*	Px-984A-932*
	in a 32K 984B chassis (standard)	Px-984B-832*	Px-984B-932*
	in a 64K 984B chassis (standard)	Px-984B-864*	Px-984B-964*
	in a 128K 984B chassis (standard)	Px-984B-828*	Px-984B-928*
	in a 984X chassis (standard)	S929-001	
	on an AT-984 (standard)	AM-0984-AT0	
	on an MC-984 (standard)	AM-0984-MC0	
	on a Q984 for MicroVAX II (standard)	AM-0984-Q20	
	on a 984-485E (standard)	PC-E984-485	
	on a 984-48K (standard)	PC-K984-485	
	option module for 984-685E and 984-785E/K/D	AS-S908-110	
	option module for Quantum all CPUs	140CRP93100	140CRP93200
Drop Adapter	for 800 Series I/O	AS-J890-101 ASP890300	AS-J890-102 ASP890300
	for 800 Series I/O with two ASCII ports	AS-J892-101 ASP890300	AS-J892-102 ASP890300
	for 800 Series I/O with built-in P/S	AS-P890-000 ASP890300	ASP890300
	for 800 Series I/O with two ASCII ports, built in P/S	ASP890300	ASP890300
	for 800 Series I/O with ASCII, built in P/S	AS-P892-000 ASP890300	ASP890300
	J291 conversion for 200 Series I/O	AS-P451-581/-681	
	J290 conversion for 200 Series I/O with ASCII without ASCII	AS-P453-582/-682 AS-P453-581/-681	AS-P453-592/-692 AS-P453-591/-691
	for Quantum I/O	140CRA93100	140CRA93200

\*These part numbers are for the entire chassis mount PLC system, including the chassis itself; x = 1 for a four-card chassis; and x = 5 for a seven-card chassis.

---

# Chapter 2

## Planning and Designing an RIO Cable System

---

### Overview

This chapter provides information on planning and designing an RIO cable system.

### What Is in This Chapter?

This chapter contains the following topics:

Topic	Page
Linear Cable Topologies	20
Hot Standby Cable Topologies	24
Trunk Splitter Use	28
Illegal Coaxial Cable Topologies	30
Using Fiber Optics in an RIO System	33
RIO System Design	40
Choosing Coaxial Cables for an RIO Network	42
Coaxial Cable Characteristics	44
Electrical Characteristics of Coaxial Media Components	45
EMI/RFI Considerations in a Coaxial Cable Routing Plan	47
Tap Connections and Locations	48
Grounding and Surge Suppression	50
Terminating a Coaxial Cable System	52
Designing a Coaxial Cable System to an Attenuation Limit	53
Attenuation Considerations in an Optical Path	57
Maximum Number of 490NRP954 Repeaters and Jitter Considerations	59
Planning RIO Drops	61

## Linear Cable Topologies

### Overview

There are many possible topologies that may be used for RIO networks. The most common RIO networks use one or two coaxial trunk cables with taps that connect via coaxial drop cables to a series of remote I/O drops. At the head-end of a trunk cable is the PLC with an RIO processor, and at each remote drop is an RIO adapter. These topologies are linear—they do not use any branches or loops in the cable layouts.

### Standard Single-cable RIO Cable Systems

A single-cable linear topology, as shown in the following illustration, is the simplest and most commonly used RIO cable system:

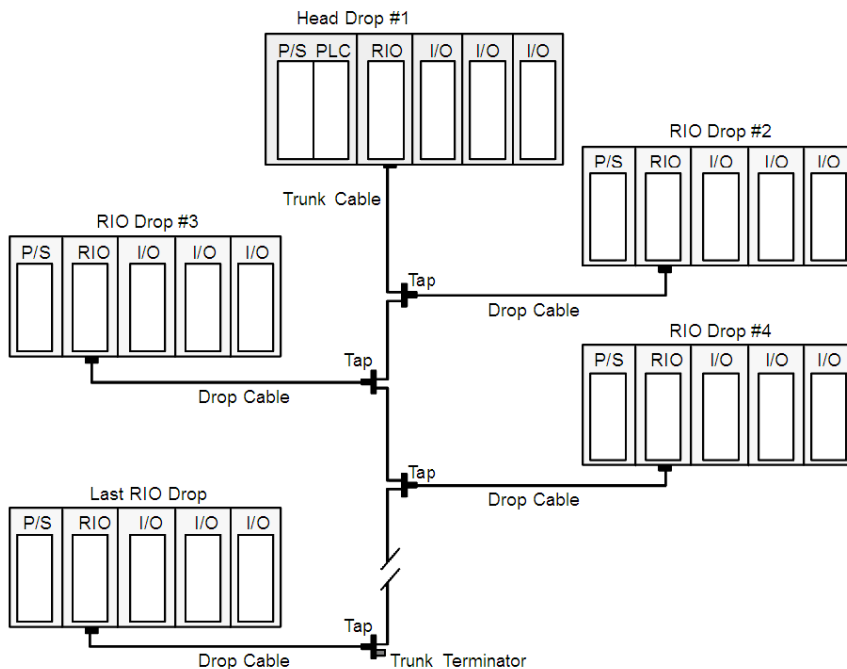

**NOTE:** Because this example uses local I/O at the head, the first remote drop in the network is I/O mapped as drop #2. If the PLC you are using does not support local I/O—e.g., the 984A/B PLCs—then the first drop in the RIO network can be mapped as drop #1.

**NOTE:** Quantums use drop #1 for local I/O. When upgrading from a 984A, B, or X PLC to a Quantum Automation Series PLC, the first drop in the RIO network will need to be changed to a drop number other than #1.

### Redundant RIO Cable Systems

If both the head processor and the drop adapters have two cable ports, then redundant linear cables can be run. A redundant topology provides two parallel paths to the same remote I/O drops. It allows you to increase the communications integrity on an RIO network, allowing the network to operate even when one cable system is damaged or malfunctioning.

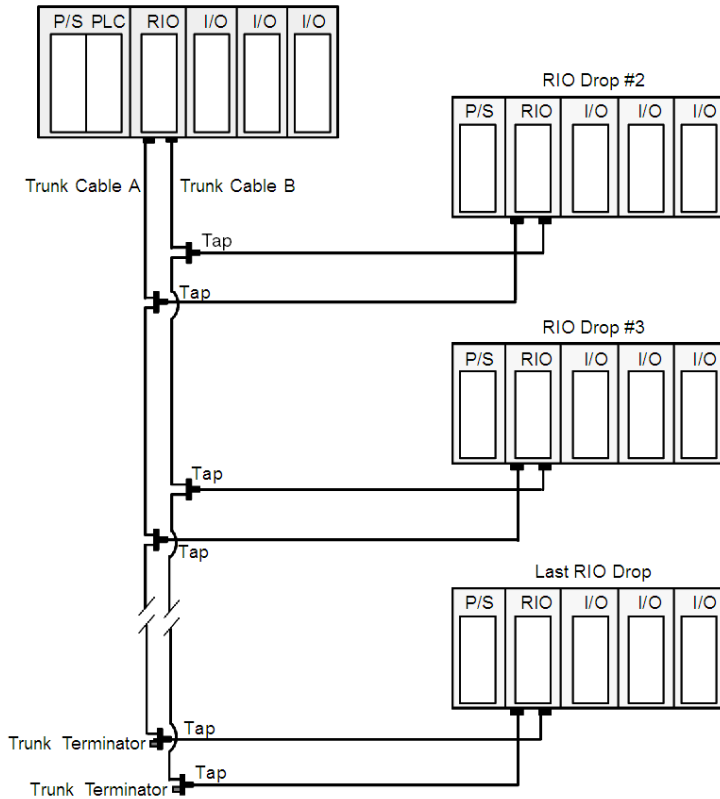

The two cables are treated as two separate networks, and each cable is an independent system running from the same RIO processor node to the same remote I/O drops. If a break occurs in cable A or cable B, an LED goes ON at the RIO head processor. The condition is also logged in words 179 ... 277 of the status table: these status words can be accessed via the STAT instruction (see *Modicon Ladder Logic Block Library User Guide*, 840 USE 101 00).

A redundant cable topology requires two RIO cable ports on the RIO processor and on all the RIO drop adapters.

### Dual Cable Systems

If your RIO processor has two cable ports, then two linear cables can be run along separate routes to different sets of remote drops. A dual cable system can be used to extend the total length of the cable system. This topology allows you to use the full dynamic range in both directions, thus allowing the cable system's total length to be extended. This topology requires a dual cable port at the RIO processor and a single cable port at each of the RIO drop adapters.

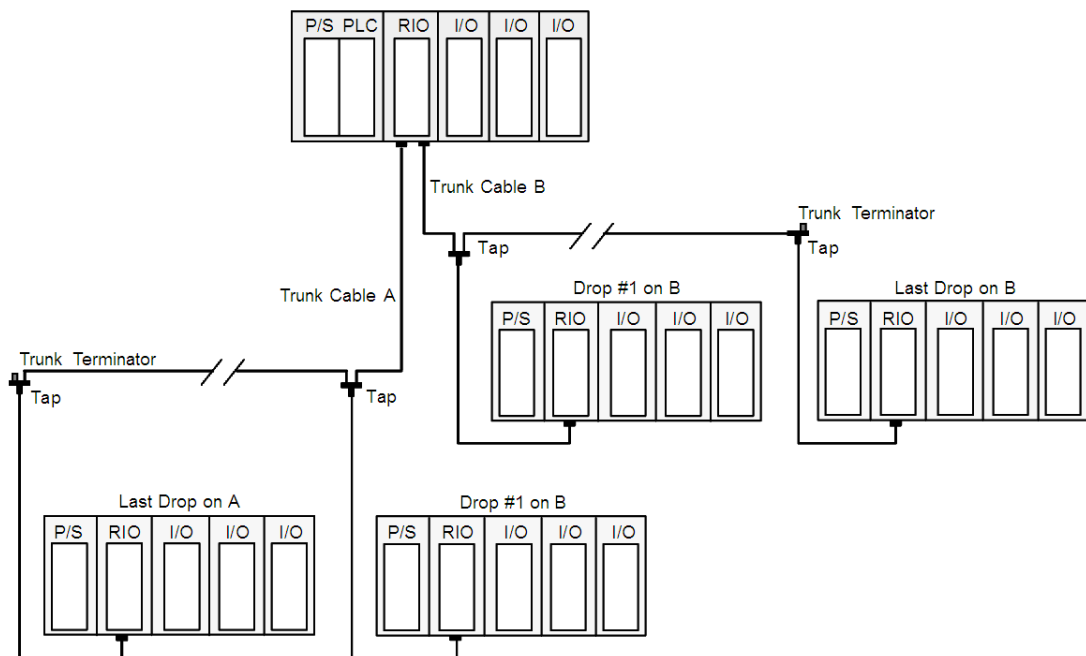

The lengths of the trunk cables and the number of drops from each do not need to be balanced in a dual cable system. In most respects, the two lines can be installed as if they were two independent cable systems, with two special considerations:

- The total number of drops on both lines must not exceed the maximum number of drops supported by the PLC
- Each drop on the two trunks must have a unique RIO network address

**NOTE:** RIO statistics using the STAT block will not provide the true status of each drop because the drops will only be attached to one of the two RIO ports at the head processor. Also, an error LED will be ON at the RIO processor.

**NOTE:**

- The maximum length of the trunk cable is determined by the specified attenuation of the cable type and the number of other cable hardware components along the network
- The minimum length permitted for a drop cable is 8.5 ft. (2.6 m)—a shorter drop cable can create tap reflections that can cause errors in the drop adapter
- The maximum coaxial drop cable length is 164 ft. (50 m)—it can be expanded with a fiber optic link
- A minimum spacing of 8.5 ft. (2.6 m) must be maintained between taps. Each unused port in a tap needs to be terminated with a Modicon 52-0402-000 Tap Port Terminator.

## Part Numbers

Part numbers for basic components and tools that may be used in linear topology coaxial cable networks are listed here to familiarize readers. Specific trunk and drop cable selection is determined using information contained in this guide. Semirigid cable components are not listed.

Description	Part Number
RG-6 Coaxial Cable	97-5750-000 (1000 ft)
RG-6 F Connector	MA-0329-001 (cassette/10)
RG-6 Cable Stripper	490RIO00400
RG-6 Connector Crimper	60-0544-000
RG-6 Cable Cutter	60-0558-000
RG-11 Coaxial Cable	97-5951-000 (1000 ft)
RG-11 F Connector	490RIO00211 (package/6)
RG-11 Cable Stripper	490RIO0S411
RG-11 Connector Compression Tool	490RIO0C411
RG-11 Cable Cutter	60-0558-000
Tap	MA-0185-100
Trunk Terminator	52-0422-000
Unused Tap Port Terminator	52-0402-000

## Hot Standby Cable Topologies

### Overview

A Hot Standby (HSBY) system is comprised of two identically configured PLCs with RIO processors and HSBY modules. The RIO heads are connected via an MA-0186-X00 splitter so that either can support the same cable system. One of the PLCs acts as the **primary** controller that communicates with the RIO network. The other PLC is the **standby** controller that maintains current state data updated from the primary controller via the HSBY module. In the event of a primary PLC failure, control responsibilities are switched over to the standby device.

### Related Documentation

See the *Hot Standby Planning and Installation Guide*, part number 840USE10600, for information regarding kits to implement Quantum Hot Standby operation, as well as information on the coaxial cable components.



### Single-cable Hot Standby System

The following is an illustration of the single-cable Hot Standby (HSBY) system.

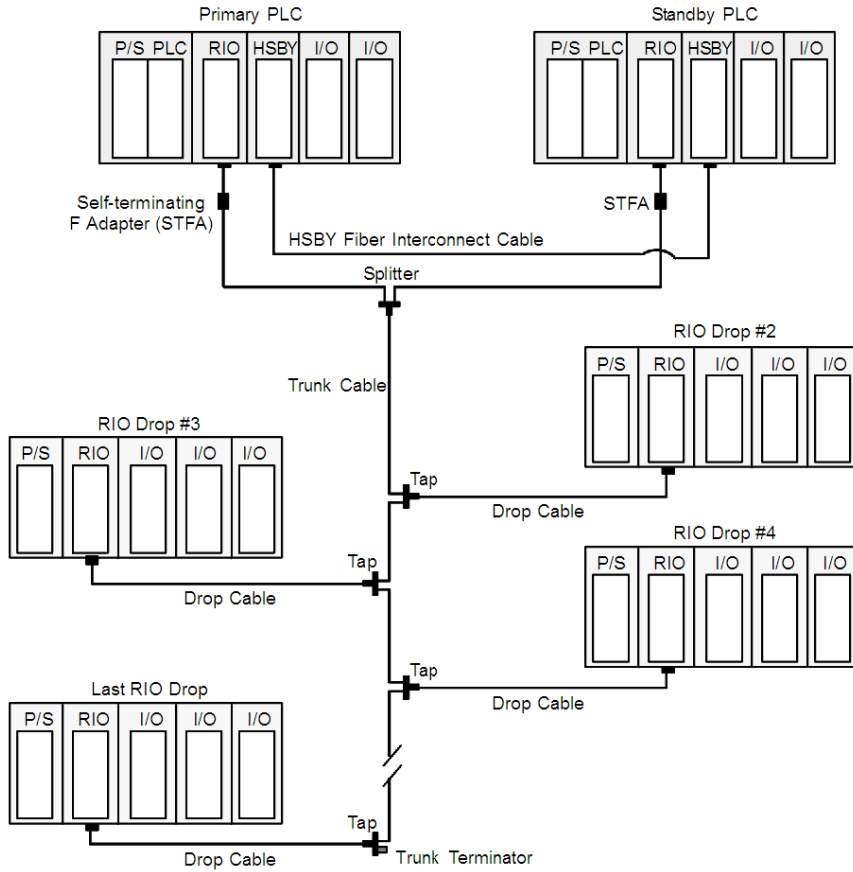

### Redundant Hot Standby Cable Systems

Using redundant cabling in a Hot Standby system creates a very powerful system with backup both at the controller head-end and along the RIO network. This topology requires the use of RIO head processors and drop adapters with two RIO cable ports, and it requires the use of two splitters.

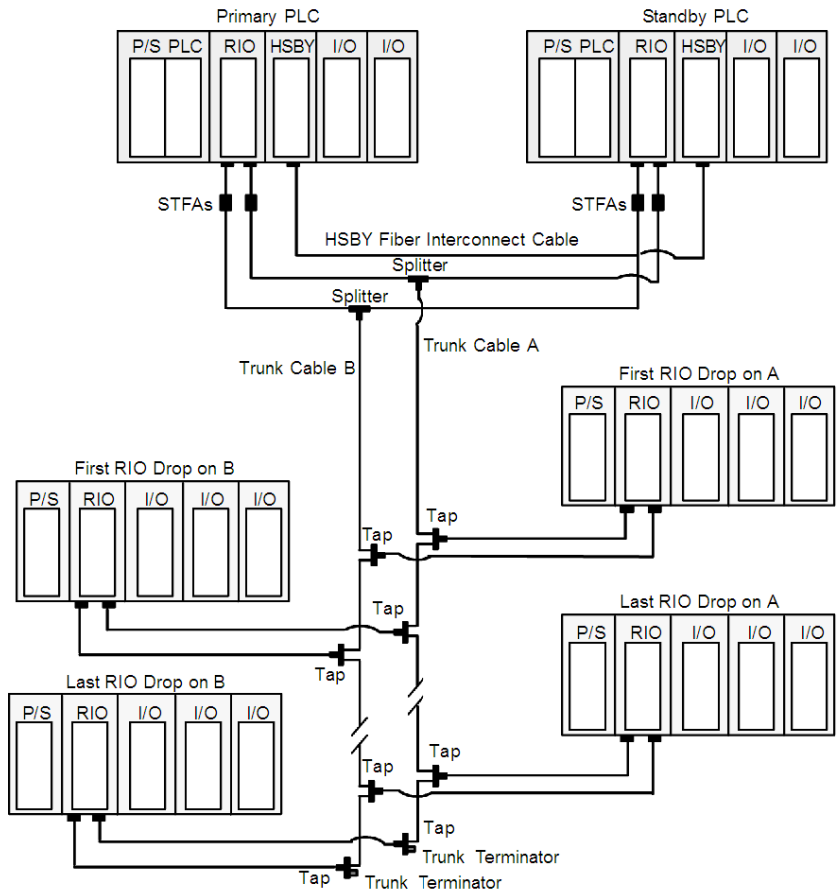

### Hot Standby Coaxial Cable Interconnection Lengths

Self Terminating Adapters (STFA) are mounted 18 in. from a HSBY RIO head. Allowable distance between an STFA and the MA-0186-X00 combiner splitter is 8-100 ft.

**NOTE:** Because Hot Standby system RIO heads communicate between themselves to verify connectivity, MA-0186-X00 splitters must be used as RIO head combiners. The MA-0331-000 splitters cannot be used due to their high port isolation quality.

Crimp-on STFA's are not available for RG-11 quad shield cable. To provide self termination when using RG-11 coax, a 52-0370-000 F to BNC self terminator and a 52-0614-000 adapter may be installed. See *Network Terminators*, [page 83](#) for RG-6 and RG-11 self terminator information. See *Providing Line Termination on the Drop Cable*, [page 124](#) for further information on terminator products and use.

### Part Numbers

Part numbers for basic components and tools that may be used in Hot Standby topology coaxial cable networks are the same as those listed in *Linear Cable Topologies*, [page 20](#). Trunk and drop cable types must be determined.

If Hot Standby kits (e.g., 140CHS32000 for Quantum) are not purchased, additional individual coaxial cable components for Hot Standby implementation that may be used are:

Part Number	Description
MA-0186-100	Splitter (required)
52-0411-000	Crimp On Adapter for RG-6 quad shield cable
52-0720-000	Self-terminating F to F adapter (check for availability)
52-0370-000	Self-terminating F to BNC adapter
52-0614-000	BNC to F adapter

## Trunk Splitter Use

### Overview

The following are examples of trunk splitter use in standalone and Hot Standby systems.

### Using a Trunk Splitter in a Standalone System

Using a single MA-0331-000 splitter as a branching device on the trunk is permitted. The original requirement when using the MA-0186-X00 as a trunk splitter was that the trunk extensions when running from it need to be balanced to prevent signal reflections. The MA-0331-000 splitter has higher port to port isolation so the balance requirement is not as important, but it should be observed as close as is practical.

The distance between an RIO head and the MA-0331-000 trunk splitter may be between 8.5 and 100 ft.

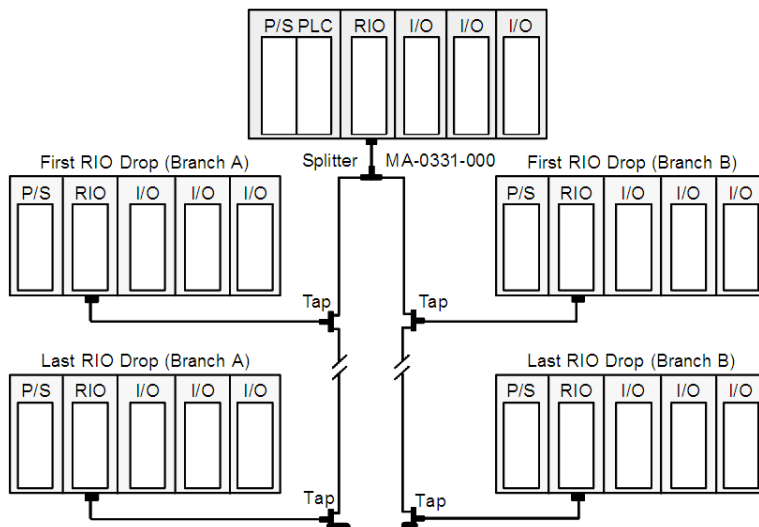

## ⚠ CAUTION

### Possible equipment failure

The use of more than one splitter as a branching device on the RIO network is *never* permitted.

**Failure to follow these instructions can result in injury or equipment damage.**

### Using a Trunk Splitter in a Hot Standby System

Using a single MA-0331-000 splitter as a branching device on the trunk in a Hot Standby system is allowed. As in standalone systems, the original requirement when using the MA-0186-X00 as a trunk splitter was that the trunk extensions running from it need to be balanced to prevent signal reflections. The MA-0331-000 splitter has higher port to port isolation so the balance requirement is not as important, although it should be observed as close as is practical.

When an MA-0331-000 trunk splitter is used in the Hot Standby network, the minimum distance between it and the MA-0186-X00 combiner splitter is 8 ft. Overall distance from the RIO head to the MA-0331-000 trunk splitter should not exceed 100 ft.

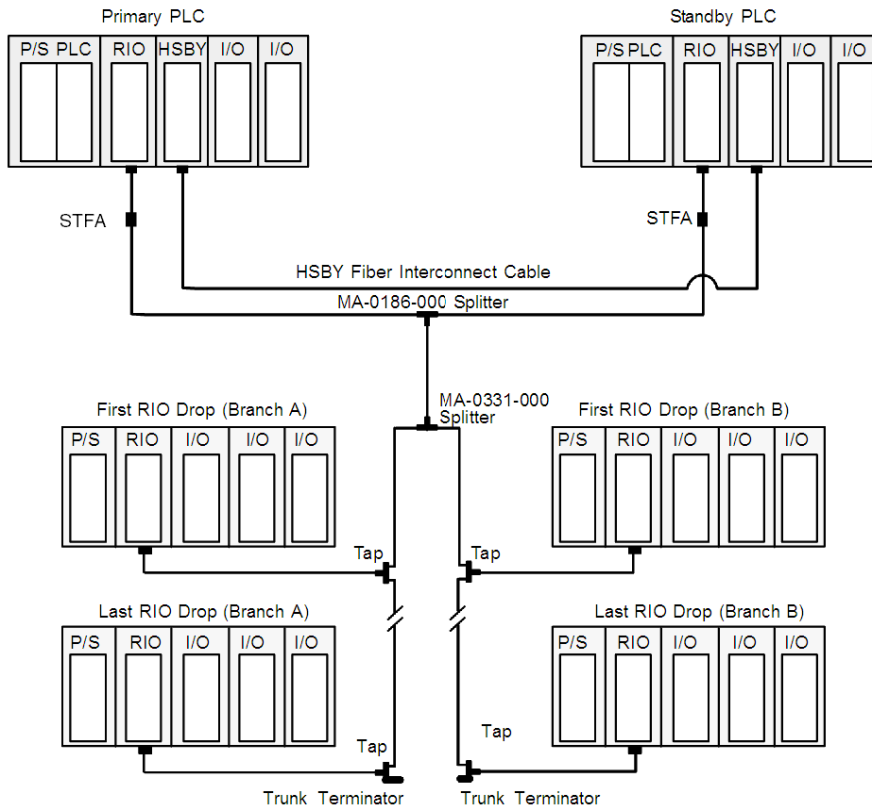

## ⚠ CAUTION

### Possible Equipment Failure

The use of more than one splitter as a branching device on an RIO network is *never* permitted.

**Failure to follow these instructions can result in injury or equipment damage.**

## Illegal Coaxial Cable Topologies

### Overview

The following are several examples of coaxial cable design topologies that are either not recommended or not permitted on an RIO network.

### Illegal Trunk Cable Termination

Remote drops cannot be connected directly to the trunk cable—i.e., a remote drop cannot be used to terminate the trunk:

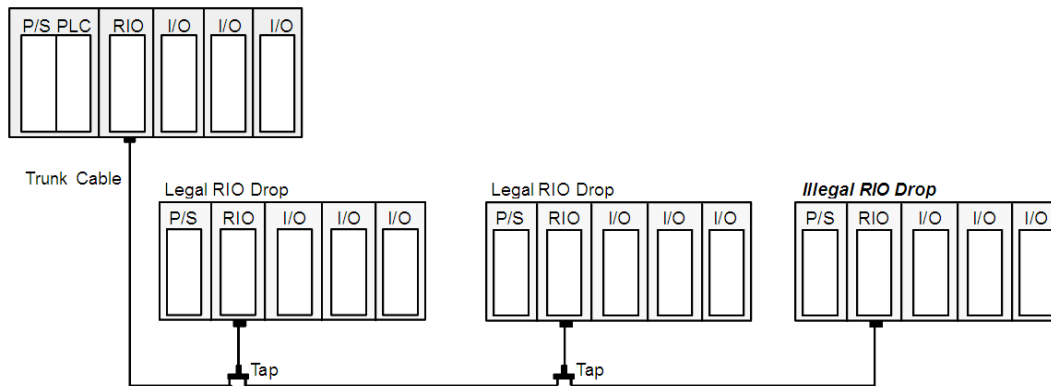

All remote drops on an RIO network must be connected to a trunk cable via a tap and a drop cable, and the last tap on a trunk cable must be terminated with a 75 Ω Modicon 52-0422-000 Trunk Terminator.

### Open Taps

If a tap is inserted on the trunk for future use and does not currently have a drop cable connected to it, it must be terminated with a Modicon 52-0402-000 Tap Port Terminator.

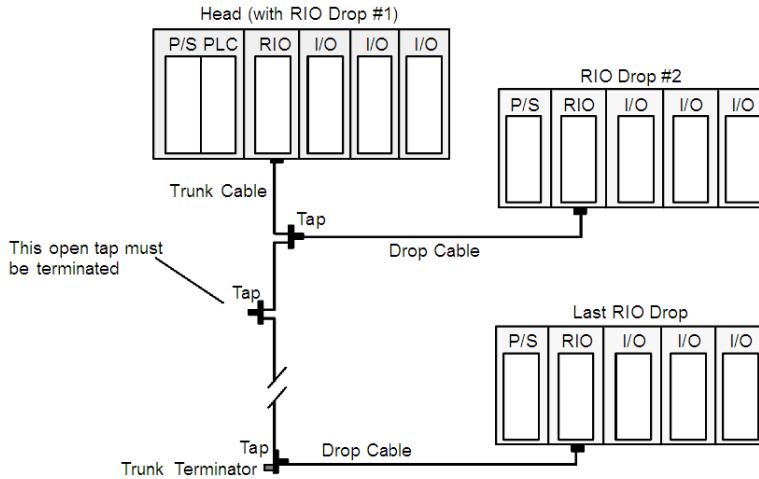

### Illegal Trunk Cable Connections

Star topologies, which use multiple splitters and multiple terminators on trunk and drop cables, and ring topologies, which form a loop of trunk cable with no terminator, are not permitted in cable systems consisting of coaxial cable only:

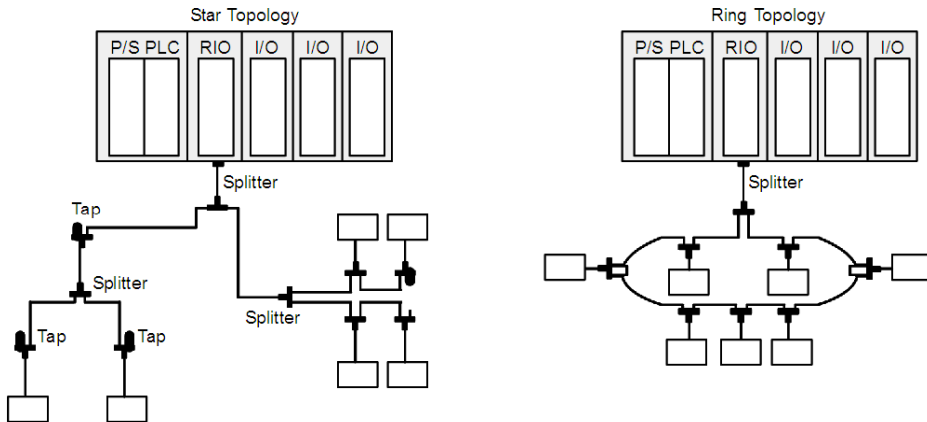

**NOTE:** These kinds of topologies are also not permissible when fiber optic cable is used. See *Using Fiber Optics in an RIO System*, page 33.

### Illegal Drop Cable Connections

Branching is not permitted on a coaxial drop cable:

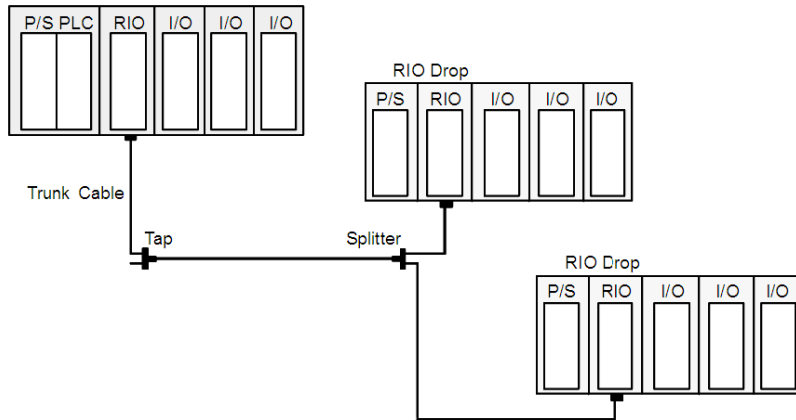

**NOTE:** Branching is permissible when fiber optic cable is used. See *Using Fiber Optics in an RIO System*, [page 33](#).



## Using Fiber Optics in an RIO System

### Overview

Fiber Optic Repeaters can be introduced in an RIO cable topology to allow you to transition from coaxial to fiber cable then back again to coaxial at one or more of the remote drops on any RIO network.

Fiber optics allow you to:

- extend the total length of the RIO installation
- significantly improve the noise immunity characteristics of the installation
- create topologies that would be illegal if built with coaxial cable alone

**NOTE:** The coaxial cable running into a fiber optic repeater is a *drop* cable—i.e., coming off a tap from the trunk cable. The coaxial cable coming out of a fiber optic repeater is a *trunk* cable—i.e., taps must be connected to it to support the drops and it must be properly terminated at the end of the run.

The RIO port on a fiber optic repeater has the same electrical specifications and restrictions as a head RIO processor with a pre-amp—e.g., the RIO receiver dynamic range is the same as the 140CRA9\*\*\*\* and 140CRP9\*\*\*\* modules.

There are 3 models of fiber optic repeaters each supporting one type of fiber optic cables:

- 140NRP95400 supports multimode optical fiber cable.
- 140NRP95401C supports single-mode optical fiber cable.
- 490NRP954 supports multimode optical fiber cable.

Multimode and single-mode fiber optic cables are not compatible.

 <b>WARNING</b>
<b>UNINTENDED EQUIPMENT OPERATION</b>
Do not link directly a multimode fiber optic repeater to a single-mode fiber optic repeater.
<b>Failure to follow these instructions can result in death, serious injury, or equipment damage.</b>

Reference	490NRP954 <i>(see page 95)</i>	140NRP95400 <i>(see page 90)</i>	140NRP95401C <i>(see page 90)</i>
Mounting	Horizontal shelf or vertical panel	Quantum Backplane	Quantum Backplane
Diagnostic Relay Features	No	Yes	Yes
High Availability System <sup>(1)</sup>	No	Yes	Yes
Fiber Optic Mode	Multimode	Multimode	Single-mode

- (1) When redundant cable system and redundant power supplies functionalities are non interrelated.  
 (2) Depending on the architecture topology, some restrictions may appear on the diagnostic relay features when 140NRP95400 and 490NRP954 fiber optic repeaters are connected together.  
 (3) The maximum length is between the head RIO module (the farther one in a Hot Standby (HSBY) system) and the last drop RIO module.

Reference	490NRP954 <i>(see page 95)</i>	140NRP95400 <i>(see page 90)</i>	140NRP95401C <i>(see page 90)</i>
Compatibility <sup>(2)</sup>	With 140NRP95400	With 490NRP954	No
Jitter Limitation	Yes <i>(see page 59)</i>	No cumulative jitter	
Maximum Distance Between Two Repeaters	3 km	3 km	16 km
Maximum Number in Bus or Self-Healing Configurations	5	12	12
Maximum Length of Fiber Optic Cable in Bus Configuration	5 km	16 km <sup>(3)</sup>	16 km <sup>(3)</sup>
Maximum Length of Fiber Optic Cable in Self-Healing Configuration (back-loop included)	10 km	16 km <sup>(3)</sup>	16 km <sup>(3)</sup>
Reference Guide	<i>Modicon Fiber Optic Repeaters User's Guide</i> , part number GM-FIBR-OPT	<i>Modicon 140NRP95400 and 140NRP95401C Fiber Optic Repeater Modules User Guide.</i>	
<p><b>(1)</b> When redundant cable system and redundant power supplies functionalities are non interrelated.</p> <p><b>(2)</b> Depending on the architecture topology, some restrictions may appear on the diagnostic relay features when 140NRP95400 and 490NRP954 fiber optic repeaters are connected together.</p> <p><b>(3)</b> The maximum length is between the head RIO module (the farther one in a Hot Standby (HSBY) system) and the last drop RIO module.</p>			

### Point-to-point Topology with Fiber Optics

The following illustration shows two segments of RIO coaxial cable connected point-to-point by two Fiber Optic Repeaters. The fiber link may be run over much longer distances than a coaxial drop cable, and through harsh environments with noise immunity that cannot be achieved with copper wire.

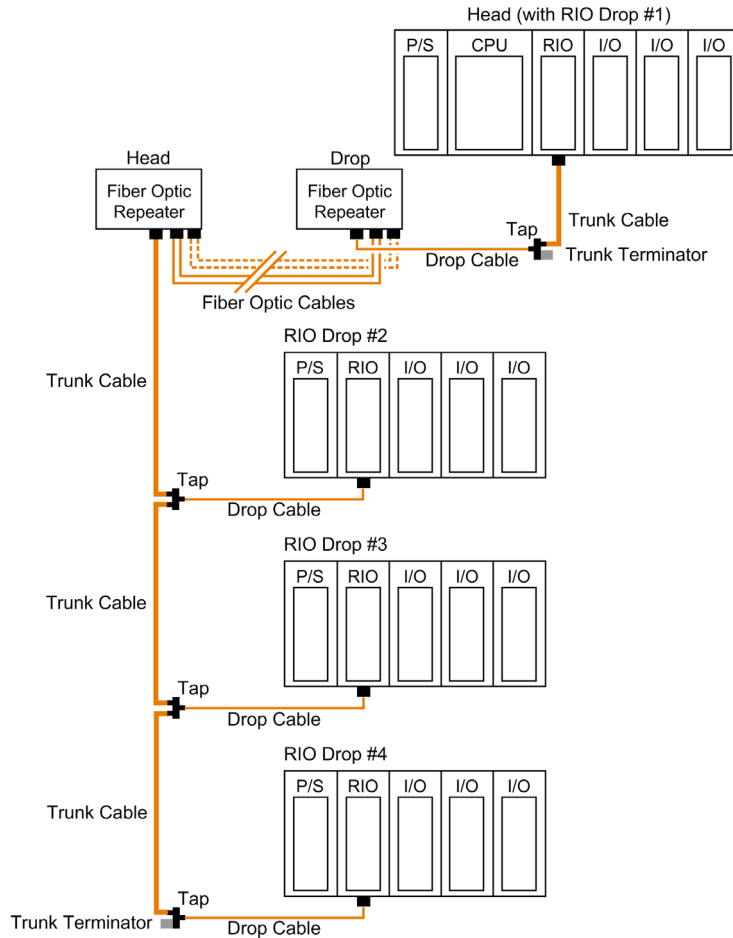

The distance between the two repeaters is limited by the maximum allowable attenuation of the fiber optic cable used in the installation. Fiber attenuation is calculated separately (*see page 57*) from coaxial cable attenuation.

**NOTE:** The repeater that has a hard-wired (coaxial) connection to the head processor at the top of the RIO network is called the *drop* repeater. The repeater that has a coaxial cable connection to the RIO drops is called a *head* repeater.



### Tree Topologies with Fiber Optics

Tree topologies, which cannot be established with coaxial cable alone (Illegal Trunk Cable Connections (*see page 31*)), can be built legally using fiber optic repeaters.

**NOTE:** The limitations in bus and self-healing configurations are applicable for each drop in tree topology.

The following tree topology is legal on an RIO fiber optic link:

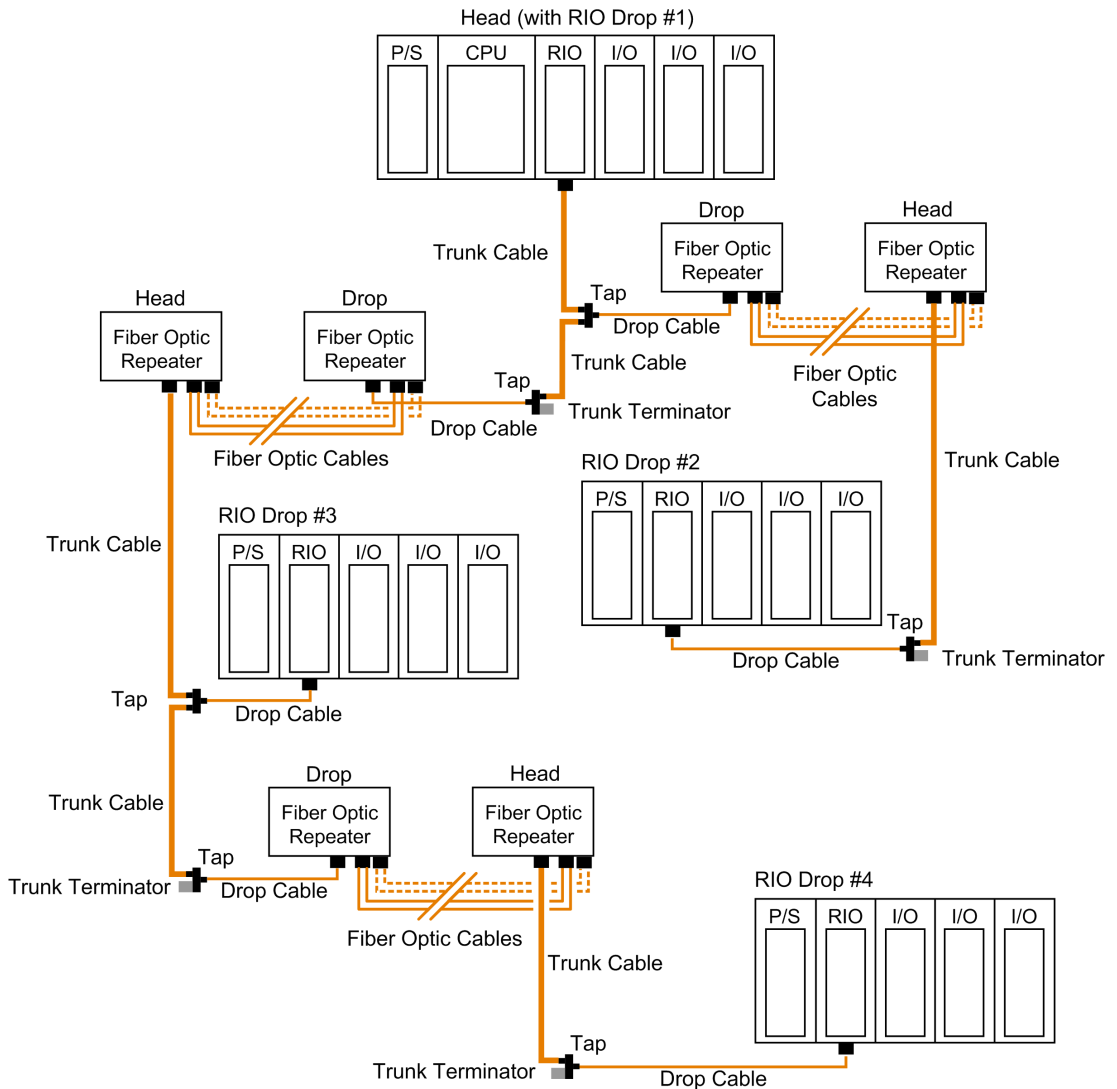

### Self-Healing Ring Fiber Optic Topology

The Fiber Optic Repeaters have special features built into the signal timing that allow multiple repeaters to be interconnected in a closed-loop ring. The advantage of a ring topology is that if a break occurs anywhere in the ring, it will reconfigure the network so that communications can continue.

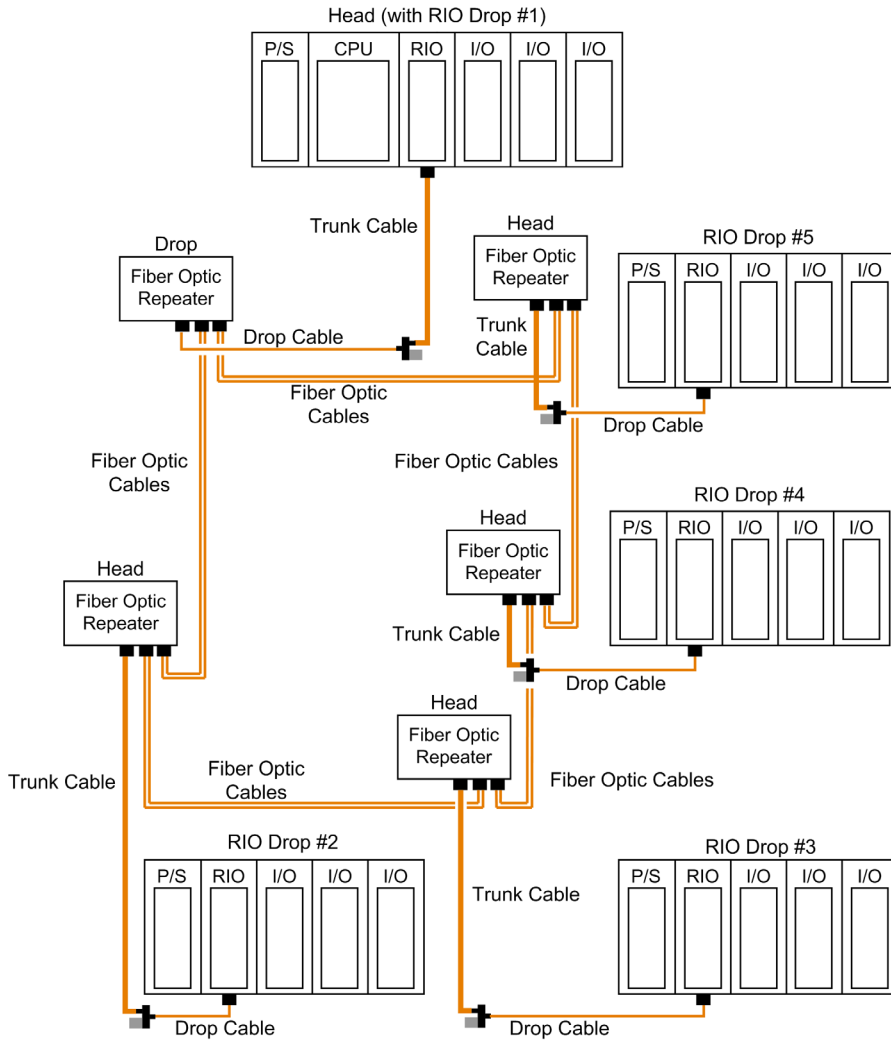

The RIO signal is sent down both legs of the ring by the drop repeater—simultaneously to the head repeaters. A feature is built into the repeaters so that when a signal is received on one of the Rx lines the other Rx channel is blanked—this prevents the same signal from being transmitted twice in the ring.

**NOTE:**

- The maximum number of 490NRP954 repeaters that can be in a ring configuration is five. This number may be reduced by the total pulse width distortion (jitter) that occurs on one system (*see page 59*).
- The maximum number of 140NRP95400 repeaters that can be in a ring configuration is twelve.
- The maximum number of 140NRP95401C repeaters that can be in a ring configuration is twelve.
- The maximum length of the fiber cable in a ring configuration is calculated in the the case of a break that occurs anywhere.

**NOTE:** No sense bit is sent in a self-healing ring topology, and fault detection can be accomplished only via visual inspection of the indicator lights on each repeater or physical status of the cable. The 140NRP95400 and 140NRP95401C are equipped with a diagnostic relay (*see page 93*) which behavior allows to detect internal or external error.

## RIO System Design

### Overview

When designing an RIO cable system, consider:

- whether you will route one or two cables to the remote drops
- the node limitations—e.g., single-port or dual port, ASCII device support
- the expansion capabilities of the PLCs—i.e., the maximum number of drops supported
- the number of nodes—head processors and drop adapters
- the locations and the environmental conditions in which these nodes must operate
- the grounding system in which these nodes must operate

### Key Elements in a Cable System Plan

The following are the key elements in a cable system plan:

- the cable system must be dedicated to RIO—no other signals or power can be applied or transmitted on this network
- the attenuation between the head processor (or the last fiber optic repeater, if an optical link is used) and any drop adapter must not exceed 35 dB at 1.544 MHz (32 dB for the host-based 984 PLCs)
- minimum bend radiuses specified for the trunk and drop cables must not be exceeded
- expansion and contraction loops should be put into the cable system to allow for temperature changes
- band marked trunk cable is useful for determining tap placement
- on the same equipotential room, the coaxial cable system should be single-point grounded within 20 ft. of the RIO processor—the central ground point may be a tap, a splitter, or a ground block
- in a case of harsh electromagnetic environment and/or distant grounding, it is recommended for communication network to use optical fiber media between different rooms, islands or buildings
- the physical cable installation must be well supported, and cable pull strength must be considered; some manufacturers suggest that RG-6 and RG-11 cable be supported at least every 50 ft; contact the manufacturer to ensure that you do not exceed the strain limit of the cable
- where rodents may be a problem, protect the cable installation by using conduit or a similar material
- precautions should be taken when the media components are installed in hostile environments where high temperatures or corrosives exist—consult cable manufacturers and/or CATV suppliers for other special products for harsh environments

**NOTE:** Document your decisions for the installer and for future reference by maintenance personnel. Use the forms provided in Planning RIO Drops (*see page 61*) to document the system.



### Planning for System Expansion

The potential for system expansion should be considered in the initial design. It is less costly to provide for expansion in the original RIO network plan than to redesign the network later. If your PLC is able to support more RIO drops than your current plan requires, consider installing additional taps along the network trunk cable.

If, for instance, you intend to use a Quantum CPU, which could support up to 31 remote drops, and your current plan calls for only 10 remote drops, you can install as many as 21 extra taps for future expansion. Remember that the unused expansion taps need to be terminated (see Network Terminators *(see page 83)*).

## Choosing Coaxial Cables for an RIO Network

### Overview

Your choice of cables for an RIO network is very important. Semirigid cable offers the highest performance trunk cable, but it requires professional installation. Flexible cable is simpler to install but has more signal loss—and thus causes more distance constraints. RG-11 flexible cable is generally recommended for use as the trunk, but RG-6 flexible cable may be used as a trunk cable on small networks. RG-6 is used most often as the drop cable.

### Coaxial Cable Construction

In all cases, we recommend the use of high grade, well shielded industrial cable for trunk and drop cables on an RIO network. Physically, the cable is a single center conductor of copper, copper-plated aluminum, or copper-plated steel surrounded by an outer conductive material, called the shield. The center conductor and shield are separated by an insulating material called the dielectric. The most common dielectric material is polyethylene foam. The shield is usually made of aluminum foil and/or copper braid or some other type of metal braid. The foil provides 100% center conductor shielding. The shield may have an insulator surrounding it called the jacket. The most common jacket material is polyvinylchloride (PVC).

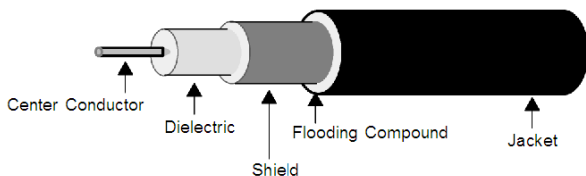

Better quality cables use multiple foil and braid shields:

Shield Type	Shield Effectiveness
Braid	Approximately 50 dB
Foil	Approximately 80 dB
Foil + Braid	Approximately 95 dB
Foil + Braid + Foil (tri-shield)	Approximately 105 dB
Foil + Braid + Foil + Braid (quad shield)	> 110 dB
Semirigid	> 120 dB

### Flexible Cable

Two types of flexible cable can be used in Modicon RIO cable systems—RG-6 and RG-11.

RG-6 is a 5/16 in. flexible cable with moderate noise immunity and moderate signal loss. The loss varies among manufacturers and cable types. Most applications use RG-6 for drop cables; RG-6 can be used as the trunk cable on small networks.

Modicon 97-5750-000 RG-6 quad shield cable can be ordered on 1000 ft. rolls; Modicon also provides pre-assembled RG-6 drop cables in 50 ft. (AS-MBII-003) and 140 ft (AS-MBII-004) lengths.

RG-11 is a 3/8 in. flexible cable with good noise immunity and low signal loss. RG-11 cable is suitable for use as trunk cable in most industrial applications and may be used as drop cable in very high noise environments. Modicon 97-5951-000 RG-11 quad shield cable can be ordered on 1000 ft rolls.

### Semirigid Cable

Semirigid cable construction is similar to that of flexible cable except that it uses a solid aluminum shield for 100% shield coverage. Semirigid cable has high noise immunity and very low signal loss, making it ideally suited for the main trunk cable when maximum distance and/or high noise immunity is needed. It is not generally used for drop cable because of its inflexibility. Semirigid cable is available in sizes that usually range from 1/2 ... 1 in. and up. Only large applications, or high noise environment applications, will need to use this type of cable.

## Coaxial Cable Characteristics

### Cable Bend Radius

All cables have a minimum allowable bend radius—i.e., a certain degree beyond which it cannot be bent—and a minimum support requirement. If the cable is bent more than the allowable bend radius or if the installation is not adequately supported, you can easily damage the center conductor, the dielectric, and the cable shield.

This damage can cause signal waveform reflections back into the cable system and distortions due to cable impedance alterations away from 75  $\Omega$ . The end result will be a series of transmission errors or a nonfunctioning cable system. The situation creates a high voltage standing wave ratio (VSWR) on the system—high VSWR causes the transmitted signal to reflect back to the source.

When designing the cable system, consult the manufacturer's specifications on the cable bend radius. Design the routing of the cable so that when rounding corners with cable, the cable is not bent more than the specification and put this specification on the design drawings.

### Cable Support

Most cable manufacturers recommended that RG-11 and RG-6 cable be supported at least every 50 ft (15 m). Consult the cable manufacturer for more detail about minimum support requirements for other types of cables.

### Cable Pull Strength

Every cable has a maximum allowable pull strength. Any cable that must be pulled through wiring ducts or conduit should have its pull strength labeled on the design drawings. If cable is pulled beyond the maximum allowable limits, the cable will stretch or break causing an impedance mismatch. The stretch or break may not be apparent in a visual inspection—e.g., the dielectric inside the cable could become damaged or the center conductor could break. Cable pull strength ratings can be obtained from the cable manufacturer—they are also listed in the cable specifications in *RG-6 Cable*, [page 68](#), *RG-11 Cable*, [page 69](#), and *Semirigid Cable Connections*, [page 119](#).

### Environmental Considerations

Cable components will degrade if subjected to extremes of temperature and humidity. Consult the manufacturer specifications on the cable components used in the RIO network to assure that they meet the requirements of the application.

Provide excess cable in each cable segment of your cable run to allow for temperature changes. Cable system components will expand and contract as a result of temperature variations. Several inches of excess cable should be provided to ensure that the cable will not be damaged by temperature changes. Consult the cable manufacturer for the expansion and contraction specifications.

## Electrical Characteristics of Coaxial Media Components

### Overview

The following electrical characteristics must be considered when choosing the media components for your network cable system. These characteristics determine the maximum length of the cable system and the number of nodes permitted on the network.

### Impedance

Impedance is the AC resistance of a cable or network component to a signal. All RIO media components have a characteristic impedance of 75  $\Omega$ , with a minimum tolerance of +/- 3  $\Omega$ . Media components that can obtain a consistent impedance as close to 75  $\Omega$  as possible yield better performance.

### Attenuation

Attenuation is the amount of signal loss through media components. Cable and other media components express attenuation in decibels (dB). Lower attenuation of media components allows for higher signal strength and longer cable distances throughout the cable system.

Depending on the hardware used, RIO networks are limited to a maximum attenuation of 35 dB from the RIO head processor (or from the last fiber optic repeater in an optical link) to any drop adapter. Although all media components have attenuation values, the primary attenuation consideration is your coaxial cable selection. A cable's ability to carry a signal is mostly determined by the physical size of the cable. A larger cable can carry a signal farther than a smaller cable. Here are some rule-of-thumb cable loss figures:

Cable Type	Attenuation
1 in. semirigid	0.09 dB/30m (100 ft) @ 5 MHz
½ in. semirigid	0.14 dB/30m (100 ft) @ 5 MHz
RG-11	0.38 dB/30m (100 ft) @ 5 MHz
RG-6	0.38 dB/30m (100 ft) @ 2 MHz

Exact attenuation specifications for all approved cables are given in *RG-6 Cable*, [page 68](#), *RG-11 Cable*, [page 69](#), and *Semirigid Cable Connections*, [page 119](#).

## Return Loss

Return loss is the measurement of reflected signal strength due to impedance mismatch. This measurement is expressed as a number of dB down from the original signal. Components with a higher return loss are better.

If every component of a network were exactly  $75 \Omega$ , the return loss would be very high. In the real world this is impossible. Even the slightest impedance mismatch will cause a portion of the signal to be reflected. This reflection can subtract from or add to the originally transmitted signal, causing distortion of the original waveform.

**NOTE:** Return loss problems may be avoided by making all trunk and drop cable purchases from the same manufacturer and the same manufacturing batch. Ask the manufacturer to pretest the cable for impedance mismatch.

## EMI/RFI Considerations in a Coaxial Cable Routing Plan

### Overview

Electromagnetic interference (EMI) and radio frequency interference (RFI) sources can be avoided by using effectively shielded cable and by using the cable away from troublesome locations.

### Guidelines for Interference Avoidance

- Avoid installation of RIO cables in trays or conduits that contain AC or DC power cable or power services.
- Separate RIO cable from power cable or power sources; trunk cable runs should avoid panels, trays, and other enclosures that contain power wires.

**NOTE:** We recommend that a spacing of 12 ... 14 in./kV of power be maintained between the RIO cable installation and power cables.

- Make sure that any RIO cable power cable crossings are at right angles only.
- Do not route trunk cable into equipment cabinets or panels—trunk cable and taps should be mounted away from cabinets or panels in a separate enclosure (One satisfactory method is to install the trunk cable in the ceiling of the facility and mount the taps within an enclosure up in the ceiling. The drop cable can then be installed down to the node.)
- Do not exceed the cable's minimum bend radius and pull strength.
- Prefer fiber optic cable media with 140NRP95400 fiber optic repeaters (*see page 90*) in high noise environment, otherwise install coaxial cable in steel conduit.

## Tap Connections and Locations

### Overview

Each tap has three ports—a trunk-in port, a drop cable port, and a trunk-out port; the RIO cables connect to the tap ports via F connectors. The taps come mounted to a plastic block that is used to isolate them from ground. They must be surface mounted to a wall or an enclosure. Make sure that no tap in the RIO system is grounded or touched by a grounded metallic surface unless it is being used intentionally as the single grounding point for the entire system.

### Using Band Marked Trunk Cable

Improper placement of taps can cause signal reflections and distortion of the signal waveform. Proper placement will keep these reflections to a minimum and avoid problems with waveform distortion. The preferred method of tap placement is on cable band markers.

**NOTE:** If taps are placed too close to each other (or too close to a splitter in a Hot Standby system), a cumulative reflection will result. To avoid this problem, install taps at least 8 ft 2 in. (2.5 m) away from one another.

Trunk cable with band markers applied at regular intervals should be purchased from the manufacturer. Intervals will vary based on the propagation of the cable. Modicon RG-11 trunk cable is band marked at 8.86 ft (2.7 m) intervals; RG-6 cable is not band marked. If you are not using Modicon RG-11 for trunk cable, you can instruct your cable manufacturer to apply marker at the required intervals. The cost to perform band marking is very small.

### Tap Port Connections

An RG-11 cable can connect directly to a tap port F connector via a Modicon 490RIO00211 F Connector installed on the end of the cable (see *F Connectors for Coaxial Cables*, [page 78](#)).

Quad shield RG-6 cable can be connected to a tap port F connector via a Modicon MA-0329-001 F Connector (see *F Connectors for Coaxial Cables*, [page 78](#)).

Semirigid cable is more difficult to connect to the two (trunk-in and trunk-out) F connector ports on the tap. Because there is only a 1 in. space between the two ports, you may not be able to fit semirigid connectors directly on both ports. To avoid this problem, we recommend that you use high quality 90° right angle F adapters such as the Modicon 52-0480-000 Right Angle F Adapter (see *F Adapters for Semirigid Cable*, [page 80](#)).



### Optional Tap Enclosure Considerations

Although not required for overall network integrity, you may consider mounting the taps in separate enclosures away from the equipment panels. Potential performance improvements include:

- Avoiding panels, trays, and other enclosures that contain power wiring
- Protecting the network from disruptions caused by accidental trunk cable damage (drop cable damage usually does not disrupt the entire network)
- Performing wiring for future system expansion within panels to avoid rerouting the cable later
- Coiling any excess cable within the tap enclosure

**NOTE:** If excess cable is to be coiled within, the recommended enclosure dimensions are 2 ft (610 mm) long by 2 ft wide by 4 in. (102 mm) deep.

Where your overall system design permits it, you may consider locating the enclosures in the ceiling of the facility to further protect against mechanical damage to the trunk and taps.

## CAUTION

### Possible Equipment Failure

Do not mount a tap within a panel or enclosure that contains control equipment—the trunk and tap become susceptible to potential problems arising from power source noise, and the cable can be damaged due to movement by workers or by poor bend radiuses.

**Failure to follow these instructions can result in injury or equipment damage.**

## Grounding and Surge Suppression

### Overview

Choose a low impedance earth ground for your cable system, preferably factory ground. Use 10 gauge wire or larger to ground the cable system. Use a common single-point ground for the cable system and for all equipment associated with the system. A separate ground—e.g., a computer ground—may actually cause more noise because the RIO nodes will not be connected to it.

### Earth Ground

A low impedance earth ground is necessary on RIO cable systems to assure safety for maintenance personnel and RIO users. The earth ground also provides a path to dissipate noise on the cable system. If the ground is poor or nonexistent, a hazardous shock problem may exist, the cable system will be susceptible to noise, and data transmission errors will occur. On the same equipotential room, the cable system should be single-point grounded within 20 ft of the RIO processor—the central ground point may be a tap, a splitter, or a ground block.

**NOTE:** All nodes connected to the cable system must be grounded. Under no circumstances should ungrounded equipment be connected to the cable system. See *Modicon Quantum Automation Series Hardware Reference Guide, Appendix D: Power and Grounding Guidelines, 840 USE 100 00*.

### Environmental Conditions

In harsh electromagnetic environment (e.g. with a lot of power, powerful speed drives, long and very disturbing power cables running, motors, welding machines, power contactors, etc...) it is recommended, for communication networks, to use optical fiber media between rooms, islands or buildings.

The following figure shows the use of fiber optic repeaters (NRP) when buildings have independant ground connections and/or grounding systems:

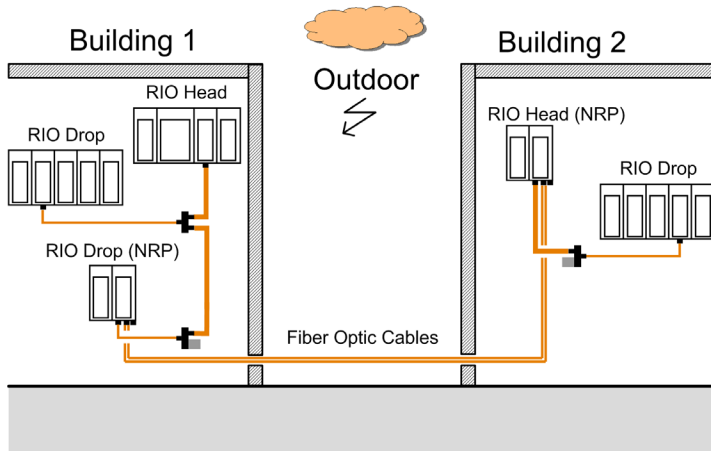

### Lightning Protection for RIO Cable Systems

Surge suppressors are recommended when a cable system is installed outdoors or in any environment where lightning protection is required. The surge suppressor must be grounded to work properly. An 8 gauge or larger diameter green or bare grounding wire is recommended. Depending on the site, installation of the suppressor can possibly introduce ground loops resulting in communication errors. Drop communication status can be monitored through the use of the STAT block mentioned in *The S908 Status Table* section of the *Monitoring Remote I/O System Status* chapter of *Modicon Ladder Logic Block Library User Guide*, 840 USE 101 00.

## Terminating a Coaxial Cable System

### Overview

Ideally, all connections on the RIO network are terminated in 75  $\Omega$  at all times. Depending on the criticality of your application, you may choose to disconnect a drop cable from a drop adapter for short-term maintenance. The trunk cable and any unused tap ports must remain terminated at all times.

### Terminating the Trunk Cable

To prevent the build-up of a standing wave that can destroy communications integrity on the network, the trunk cable must be terminated at all times with a Modicon 52-0422-000 Trunk Terminator (see *Network Terminators*, page 83). The trunk terminator is inserted in the trunk-out port of the last tap on the trunk cable. Do not terminate a trunk cable by connecting it directly to the drop adapter.

### Terminating Unused Tap Ports

Unused taps may be installed along the trunk for future system expansion. These taps will not have drop cables connected to them, and they must be terminated at all times with Modicon 52-0402-000 Tap Port Terminators (see *Network Terminators*, page 83).

### Terminating the Drops

Open connections on a drop cable can subject the network to impedance mismatches and retries. Your application may be able to tolerate these errors for short-term maintenance—e.g., swapping a device in the drop—but if you intend to leave the drop cable disconnected from the drop adapter for a long time or if you are running a critical application elsewhere on the network, you should put a 75  $\Omega$  terminator on the drop cable. You can install a female F connector on the drop cable at the time you disconnect it, then install a Modicon 52-0402-000 Tap Port Terminator. The drop will always remain terminated as long as the cable is connected to the RIO drop adapter, even when the device is turned OFF or removed from the I/O rack (*exception: the adapter devices and Motion modules in RIO Network Cable System*, page 16).

Optionally, you may design a mechanical terminator into all the drop cables—such as a Modicon 52-0411-000 Self-terminating F Adapter; this adds up-front cost to your system design but assures you of a completely balanced system at all times.

## Designing a Coaxial Cable System to an Attenuation Limit

### Overview

Attenuation happens naturally as a communication signal passes through taps, splitters, splices, cable, connections, and feed-through terminators. Your goal as designer is to provide successful RIO services while holding the attenuation to a maximum of 35 dB (32 dB in the case of the 984 host-based PLCs) from the head processor to any drop adapter on the network.

**NOTE:** If your cable design exceeds the maximum attenuation limit for your PLC, transmission errors can occur on the network.

### Cable Attenuation

The most important decision the system designer must make with regard to signal loss is the type of cable used in the system. Many designers use semirigid cable for the trunk cable in high noise environments or when maximum distance is necessary. But the majority of RIO networks use the more flexible RG-6 and RG-11 cables.

RG-6 can be used as a trunk cable, but its best use is as a drop cable. It can be used as the trunk on small networks. RG-6 has more attenuation than RG-11. See *RG-6 Cable, page 68* for cable attenuation values for RG-6 at 1.544 MHz, the RIO network transmit frequency. See *RG-11 Cable, page 69* for cable attenuation values for RG-11 at 1.544 MHz.

### Tap Attenuation

All drop adapters must be connected via a tap—never directly to a trunk cable. A direct trunk connection causes a severe impedance mismatch. All RIO taps have a tap drop loss of 14 dB and an insertion loss of 0.8 dB:

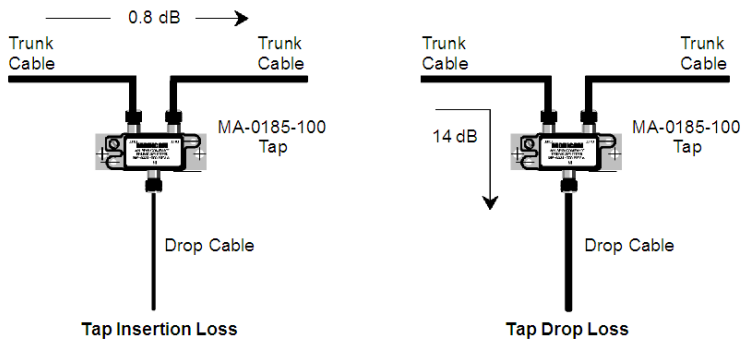

### Calculating Maximum System Attenuation

To calculate maximum attenuation, add all sources of attenuation between the RIO head processor and a drop adapter; the total loss must not exceed 35 dB (32 dB for controllers without pre-amps). The maximum attenuation for the system is generally measured from the RIO processor node to the last drop adapter on the network. The last adapter usually represents the maximum loss of the entire cable system. There are exceptions however—adapters near the end of the cable system with long drop cables may have greater attenuation.

Maximum system attenuation at 1.544 MHz can be calculated as follows:

$$\text{dB loss} = \text{TCA} + \text{DCA} + \text{TDA} + (\text{NOS} \times 6) + (\text{NOT} \times 0.8)$$

where:

- TCA = the trunk cable attenuation from the head to the end of the trunk
- DCA = the drop cable attenuation, generally at the last drop
- TDA = 14 dB, the tap drop attenuation
- NOS = the number of splitters in the system
- NOT = the number of taps between the last node and the head

**NOTE:** On a network using dual or redundant trunk cables, calculate attenuation on each separately. Each trunk on a dual or redundant RIO network can handle attenuation up to 35 dB (or 32 dB).

**NOTE:** Use (NOS x 3.5) if MA-0331-000 is to be installed. See *Splitter Specifications*, [page 76](#).

### Calculating Attenuation on a Coaxial Network—An Example

Here is a sample calculation of total attenuation in a five-drop RIO cable system. The calculation is made between the head processor and the adapter at drop 5. The distance between the head and the last tap is 2179 ft.

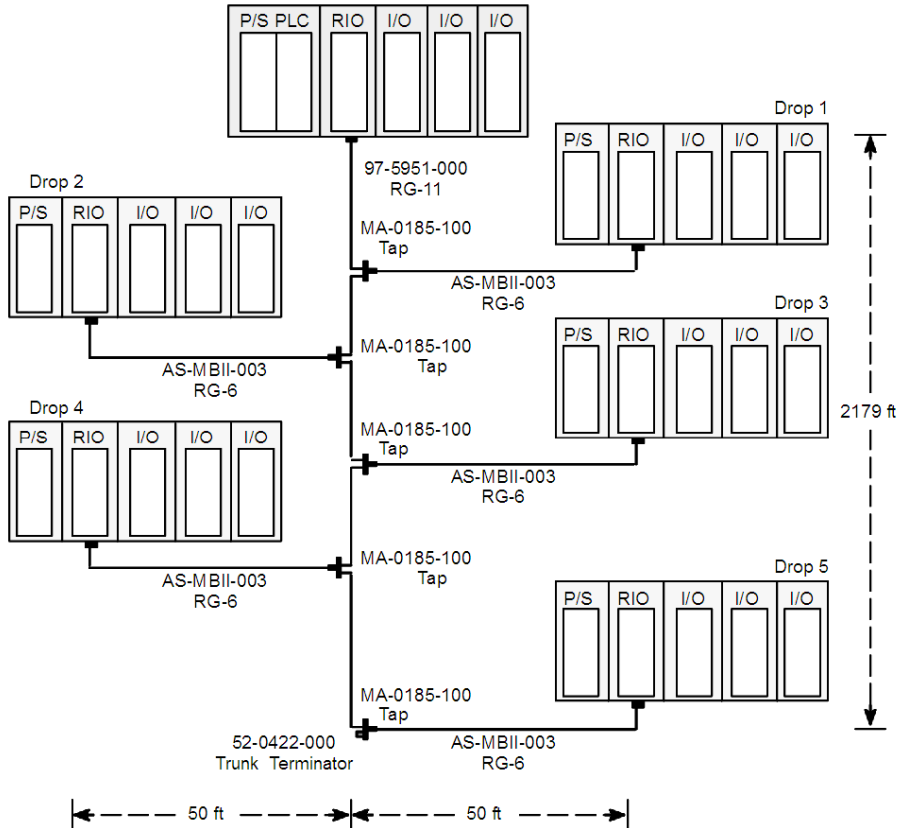

This system uses RG-11 cable for the trunk; for illustration purposes, its specified attenuation is 0.24 dB/100 ft at 1.544 MHz. Running to the adapter at drop 5 is a Modicon AS-MBII-003 RG-6 drop cable, a 50 ft cable with an attenuation of 0.3 dB. To calculate end-to-end attenuation on the trunk cable (TCA), multiply 0.24 dB (the trunk attenuation per 100 ft) by 21.79:

$$TCA = 0,24B \times 21,79 = 5,23dB$$

Each drop cable is run from a Modicon MA-0185-100 tap in the trunk cable. Four of these taps lie between our two end points, and we must calculate their tap insertion loss (TIL):

$$TIL = NOT \times 0,8dB = 4 \times 0,8 = 3,2dB$$

The drop cable attenuation (DCA) at drop 5 has been predetermined as 0.3 dB. The attenuation of the tap (TDA) at drop 5 is 14 dB. Since this system does not use a splitter, the NOS is 0.

Thus, the total attenuation for this RIO network is:

$$5,23 + 0,3 + 14 + 3,2 = 22,73dB$$

This example shows a properly designed RIO cable system with:

- total attenuation less than 35 dB
- no drop cables longer than 164 feet (50 m)
- combined cable distance (drop and trunk cables) less than 8400 ft (2560 m)



## Attenuation Considerations in an Optical Path

### Overview

Attenuation that occurs on an RIO fiber optic link is independent from attenuation on the coaxial cable system. Signals that are attenuated no more than 35dB after traveling through a coaxial cable section are converted in the fiber repeater circuitry to levels usable in the fiber link. Attenuation occurs on the fiber optic link. Receiving fiber repeaters convert the signal back to a full strength coaxial cable signal. An 35 dB attenuation level will be available for use over the next copper section.

As with coaxial cable, size and components used will determine a fiber optic link attenuation. The table below shows allowable attenuation or power loss budget for the connecting repeaters to operate properly. The specified power loss budget is in addition to loss introduced by two connectors. Other components such as splices and the fiber cable loss must be subtracted from the budget.

Fiber Type	Core Diameter	Attenuation	Optical Power Loss Budget
Single mode	9/125 $\mu\text{m}$	0.45 dB/km	8.0 dB
Multimode	50/125 $\mu\text{m}$	3.5 dB/km	7.0 dB
	62.5/125 $\mu\text{m}$	3.5 dB/km	11.0 dB
	100/140 $\mu\text{m}$	5.0 dB/km	16.5 dB

To illustrate the fiber optic loss, an uninterrupted run of 50/125  $\mu\text{m}$  fiber optic cable that has an attenuation of 3.5 dB/km could be 2 km long.

### Minimum Distance between Repeaters

There is no minimum distance requirement when using 50/125 or 62.5/125  $\mu\text{m}$  fiber cable.

If the larger diameter 100/140  $\mu\text{m}$  cable is used, it is possible to overload a repeater's receiver port circuitry. When no components are added in the fiber link made up of this sized cable, minimum distance between repeaters is 1.2 km. Fiber link length may be reduced proportionately as components are introduced.

**NOTE:** For measurements purposes, note that repeater transmitters have a maximum optical power of  $-4$  dBm when 100/140  $\mu\text{m}$  cable is used. Maximum repeater received signal is  $-10$  dBm for any cable size used.

### Example—Attenuation on a Simple Optical Link

The following figure shows an example of a point-to-point optical connection that uses 3 km of 62.5/125  $\mu\text{m}$  multimode fiber cable. There is one splice in the cable connection:

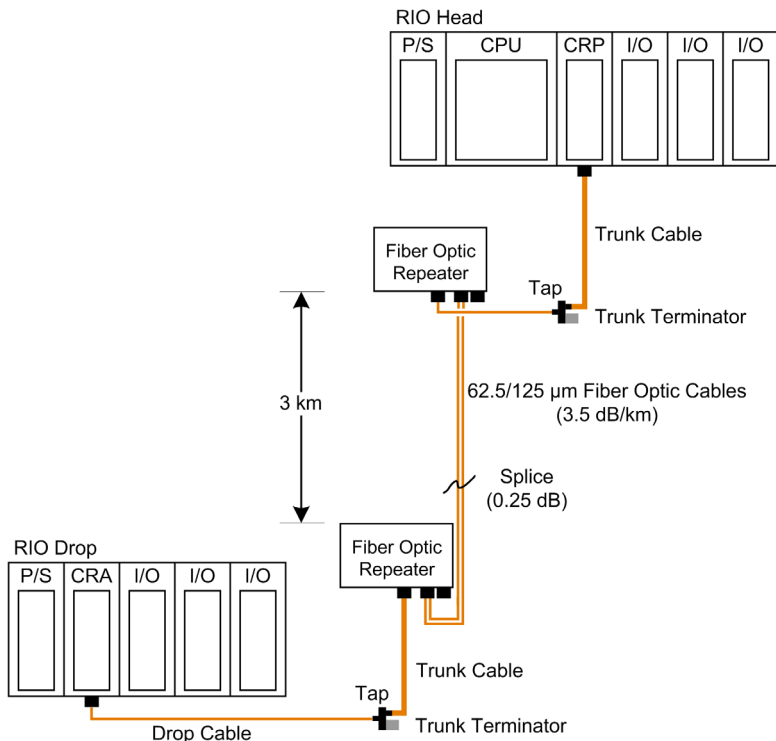

The specified power loss budget for a link using this optical cable is 11 dB. We know that the cable’s attenuation over 3 km is  $3.5 \text{ dB/km} \times 3 = 10.5 \text{ dB}$ , and we are given an attenuation of 0.25 dB for the cable splice. Thus, we have a total optical power loss of 10.75 dB on the fiber optic link, which is under power loss budget and therefore conform to the expectations.

## Maximum Number of 490NRP954 Repeaters and Jitter Considerations

### Overview

Due to the cumulative effects of reactive components, the maximum number of 490NRP954 repeaters in a linear network is five. This number may be reduced by the system's total pulse width distortion, or jitter. The table below shows jitter contributed by recommended fiber optic cables.

Core Diameter	Jitter
50/125 $\mu\text{m}$	3.0 ns/km
62.5/125 $\mu\text{m}$	5.0 ns/km
100/140 $\mu\text{m}$	7.5 ns/km

Fiber repeater jitter effect is analogous to tap loss in coaxial cable networks. The fiber to fiber jitter contribution is 10 ns and can be compared to tap insertion loss. The fiber to coaxial cable jitter contribution is 20 ns and comparable to tap drop loss.

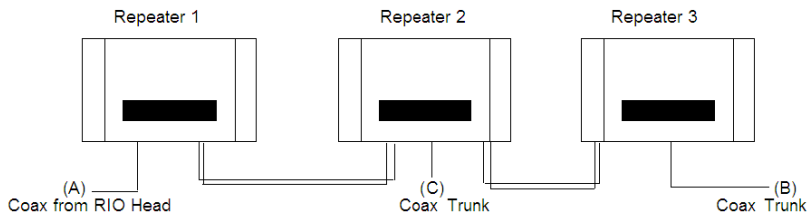

in the diagram above, jitter contribution is 50 ns from point A to point B. The following represents individual jitter contributions as shown in the diagram:

- 20 ns for Repeater 1 from the coax connection (A) to the fiber cable
- 10 ns for Repeater 2 from its fiber cable input to its fiber cable output
- 20 ns for Repeater 3 from its fiber cable input to the coax connection (B)

Jitter contribution as measured from the coax input on Repeater 1, point A to the coax connection at Repeater 2, point C is 40 ns. In both repeaters, the coax and fiber interfaces contribute 20 ns to jitter.

The total allowable jitter in a fiber network is 130 ns. Jitter effects from fiber links separated by a coaxial cable segment are cumulative. Using the diagram above and presuming the fiber cable contribution to be 5 ns, total jitter from point A to point B is 55 ns. If this network was duplicated and separated by a coaxial cable segment, then the total fiber network jitter contribution would be 110 ns between the RIO head and the last drop.

### Connecting More than Five Drops with 490NRP954 Fiber Optic Repeaters

The accompanying illustration shows how six RIO drops may be interconnected using fiber optic cable but still remain within the maximum allowable limit of five 490NRP954 repeaters. Installers are cautioned against using ring configurations involving more than five RIO repeaters. In the event of a break in the fiber cable, a linear configuration will be the result and communication errors could occur if too many repeaters are connected together. In the following illustration, dotted lines show three and four RIO repeater ring configurations.

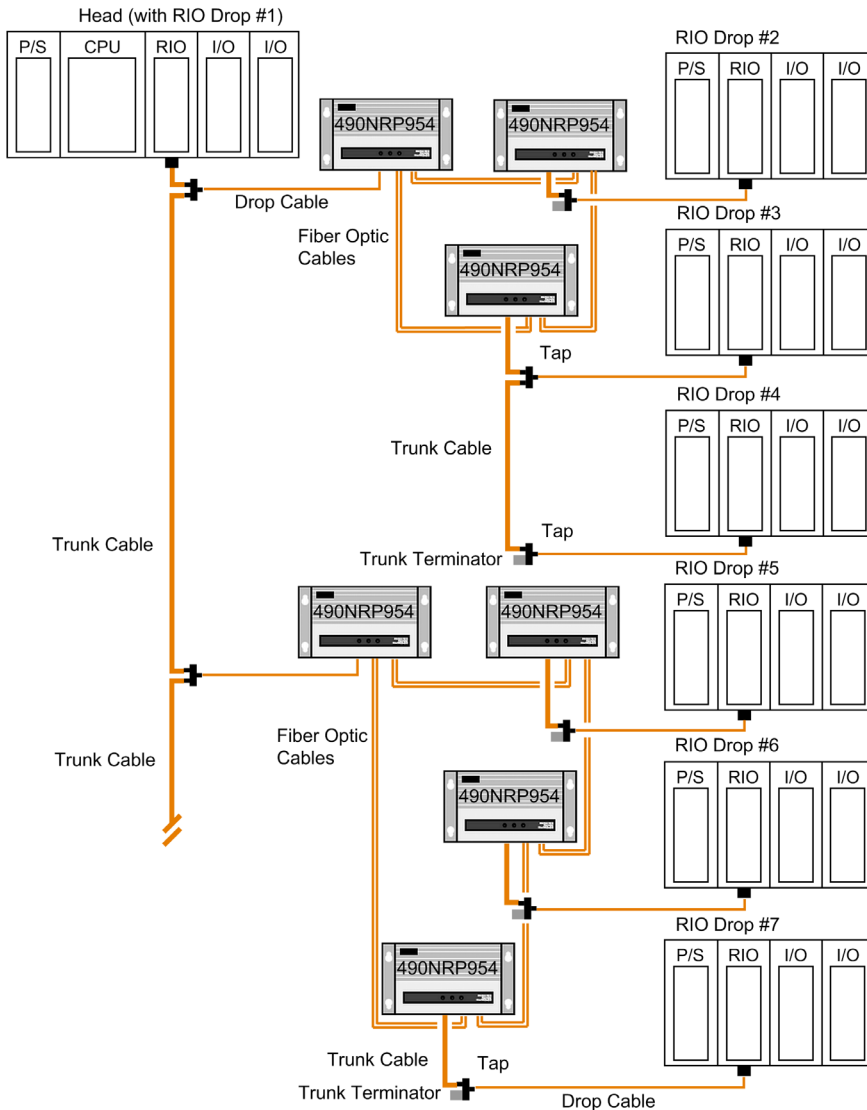

## Planning RIO Drops

### Overview

The maximum length for Modicon’s recommended drop cable is 164 ft (50 m). Keeping the drop cable lengths within this limit helps reduce attenuation on the drop and noise problems on the system. The minimum length for a drop cable is 8.53 ft (2.5 m)—shorter drop cable generates unacceptable signal reflections from the tap.

RG-6 is the more commonly used drop cable—it has fair noise immunity and good flexibility. RG-11 cable can also be used—it has better noise immunity and lower loss; RG-11 is recommended in high noise environments.

### Connecting the Drop Cable to the Drop Adapter

All drop adapters connect to a coaxial drop cable via either an F connector or a BNC connector:

RIO Adapter	RIO Cable Connection	Drop Termination
J890/J892-00x	BNC Connector	External
J890/J892-10x*	BNC Connector or F Connector(s)	In the drop adapter
ASP890300	F Connector(s)	In the drop adapter
P890/P892		
P451/P453		
140CRA93100/93200		

\*The older J890/J892-00X adapters use a BNC connector and require a 75 Ω inline terminator in drop cable.

Each drop adapter must be connected separately to a tap port. The tap isolates the drop from other drops on the network and also from the trunk cable. Multiple adapters cannot be connected on the same port of a tap. Since an adapter is not directly connected to any other node on the network, most installation and noise-related problems at a drop will not reflect across the entire RIO system.

RIO drop adapters cannot be connected directly to the trunk; they must be connected to a drop cable that is connected to a tap. Direct connection of adapters will cause a severe trunk impedance mismatch.

### Minimizing Low Receive Signal Level Problems

Some RIO processing devices have a dynamic range of +0 dBmV to +35 dBmV for receiving signals. Any signal below +0 dBmV cannot be received. No indication will be given that the signal is too low, but signal levels that vary above and below this figure will exhibit an increased bit error rate. (This is why the attenuation between any two nodes must not exceed 32 ... 35 dB.)

Problems related to dynamic range can be difficult to find, and can vary from day to day. Therefore, a properly designed system should provide a sufficient margin of error that allows for variances in the signal level—e.g., a receive level of +1 dBmV or above, attenuation of 32 dB between the RIO head-and the adapter at the most remote drop.

### Documenting Your Cable System Design

The cable system should be fully documented. As you work with the installer to determine a full list of requirements, make a detailed topological drawing of the system layout. The detailed plan should include the cable types, all the cable system hardware in position, and the complete cable routing plan.

As a starting point, you can document the design in less detail using the specification forms that follow. This initial plan does not give the installer all the routing information, but does give the most important information.

<b>Customer:</b>	<b>Network:</b>
<b>Location:</b>	<b>Plant:</b>
<b>Revision/Approved by:</b>	<b>Date:</b>
<b>Trunk Cable Materials</b>	
Trunk Cable Manufacturer:	
<p style="text-align: center;">Model #</p> <p style="text-align: center;">Quantity Needed:</p> <p style="text-align: center;">dB Loss (per 100 ft. or m):</p> <p style="text-align: center;">Maximum Pull Strength (lb. or kg)</p>	
Trunk Cable Connector Manufacturer:	
<p style="text-align: center;">Model #:</p> <p style="text-align: center;">Quantity Needed:</p>	
Trunk Terminator Manufacturer:	
<p style="text-align: center;">Model #:</p> <p style="text-align: center;">Quantity Needed:</p>	
Trunk Splice Manufacturer:	
<p style="text-align: center;">Model #:</p> <p style="text-align: center;">Quantity Needed:</p>	



Drop Cable and Tap Materials	
Tap Manufacturer:	Model #: Number of Ports: Through Loss (dB): Drop Loss (dB): Quantity Needed:
Tap Manufacturer:	Model #: Number of Ports: Insertion Loss (dB): Drop Loss (dB): Quantity Needed:
Tap Port Terminator Manufacturer:	Model #: Quantity Needed:
Misc. Connector Manufacturer	Model #: Quantity Needed:
Misc. Connector Manufacturer	Model #: Quantity Needed:

Trunk Cable Length			
Tap Number	Trunk length (from head)	Trunk Length (from last tap)	Drop Attenuation (other comments)







---

# Chapter 3

## RIO Network Hardware Components

---

### Overview

This chapter provides information on RIO network hardware components.

### What Is in This Chapter?

This chapter contains the following topics:

Topic	Page
RG-6 Cable	68
RG-11 Cable	69
Semirigid Cable	70
Selecting Fiber Optic Cable	71
Hardware Overview	72
Tap Specifications	74
Splitter Specifications	76
F Connectors for Coaxial Cables	78
F Adapters for Semirigid Cable	80
BNC Connectors and Adapters	81
Network Terminators	83
Self-terminating F Adapter Options	85
Ground Blocks	87
Surge Suppressors	88
140NRP95400 and 140NRP95401C Fiber Optic Repeater Modules	90
490NRP954 Fiber Optic Repeater	95
Recommended Materials for Multimode Fiber Optic Links	99

## RG-6 Cable

### Overview

The following table shows specifications for the Modicon 97-5750-000 RG-6 cable (available in 1000 ft rolls):

Modicon 97-5750-000 RG-6 Cable (Belden 3092A)	
Attenuation	0.38 dB/100 ft @ 2 MHz 0.36 db/100 ft @ 1.544 MHz, RIO Transmit Frequency
Impedance and Tolerance	75 $\Omega$ (+/- 3 $\Omega$ )
Velocity of Propagation	82%
Capacitance	16.2 pF/ft
Type of Shield	Bonded Foil Quad Shield
Type of Jacket	PVC
UL/NEC Rating	CMR or CL2R
Minimum Bend Radius	3 in.
Maximum Pull Strength	162 lb

### Modicon Pre-assembled Drop Cable

Modicon offers pre-assembled drop cables, built with high quality F connectors, a self-terminating F adapter, and a high quality quad shield RG-6 cable. Each assembly is fully tested and certified before shipment to assure conformance to RIO specifications. Assemblies are available in two standard lengths—50 ft (15 m) assembly (AS-MBII-003) and 140 ft (42 m) assembly (AS-MBII-004).

Modicon Pre-Assembled Drop Cable Specifications		
Tested Frequency Range	500 kHz ... 30 MHz	
Impedance	75 $\Omega$ (+/- 2 $\Omega$ )	
Attenuation at 1.5 MHz	50 ft length 140 ft length	0.3 dB maximum 0.7 dB maximum
Return loss	24 dB minimum	
Tests Performed	Attenuation Sweep Test, Return Loss Sweep	

### Recommended RG-6 Plenum Cable

Belden recommends 3132A as a plenum-equivalent RG-6 cable. Contact Belden technical support for connector and stripper recommendations. See *RIO Cable Material Suppliers*, [page 153](#) for contact information.

## RG-11 Cable

### Overview

The following table shows the specifications for the Modicon 97-5951-000 cable, which is available in 1000 ft rolls.

<b>Modicon 97-5951-000 RG-11 Cable (Belden 3094A)</b>	
Attenuation	0.38 dB/100 ft @ 5 MHz 0.17 dB/100 ft @ 1.544 MHz, RIO Transmit Frequency
Impedance and Tolerance	75 $\Omega$ +/- 3 $\Omega$
Velocity of Propagation	82%
Capacitance	16.2 pF/ft
Type of Shield	Bonded Foil Quad Shield
Type of Jacket	PVC
UL/NEC Rating	CMR and CLR2
Minimum Bend Radius	4.5 in. (114.3 mm) (estimated)
Maximum Pull Strength	300 lb (estimated)

### Recommended RG-11 Plenum Cable

Belden recommends 3095A as a Plenum-equivalent RG-11 cable. Contact Belden technical support for connector and stripper recommendations. See *RIO Cable Material Suppliers*, [page 153](#) for contact information.

## Semirigid Cable

### Overview

The following tables show the specifications for recommended semirigid cables.

<b>CommScope QR 540 JCA</b>	
Attenuation	0.14 dB/100 ft @ 5 MHz
Impedance and Tolerance	75 $\Omega$ +/- 2 $\Omega$
Velocity of Propagation	88%
Capacitance	15.3 pF/ft
Type of Shield	Aluminum
Type of Jacket	Polyethylene
Minimum Bend Radius	5.0 in.
Maximum Pull Strength	220 lb

<b>CommScope QR 860 JCA</b>	
Attenuation	0.09 dB/100 ft @ 5 MHz
Impedance and Tolerance	75 $\Omega$ +/- 2 $\Omega$
Velocity of Propagation	88%
Capacitance	15.3 pF/ft
Type of Shield	Aluminum
Type of Jacket	Polyethylene
Minimum Bend Radius	7.0 in.
Maximum Pull Strength	450 lb

---

## Selecting Fiber Optic Cable

### Overview

If you are using Fiber Optic Repeaters in your RIO network, there are several parameters you need to consider, among them cable attenuation and cable bandwidth. Parameters are specified by the cable manufacturer and are based on:

- the cable index—use graded-index cable only
- the wavelength of the optical signal in the RIO optical link—  
**multimode:** 820 nm  
**single-mode:** 1300 nm
- the fiber size—  
**multimode:** 50/125  $\mu\text{m}$ , 62.5/125  $\mu\text{m}$ , or 100/140  $\mu\text{m}$   
**single-mode:** 9/125  $\mu\text{m}$

For most optical cable links in multimode, the use of 62.5/125  $\mu\text{m}$  cable is recommended because of its relatively low loss and signal distortion. In applications where high optical power is required—e.g., to support additional optical devices such as splitters or star couplers—the 100/140  $\mu\text{m}$  cable should be used. Refer to Calculating Attenuation on an Optical Path ([see page 57](#)) for more details on design considerations.

Many cable vendors offer multiple choices for a variety of code ratings:

- From the variety of cables, e.g., AMP or Belden offerings—select the one that meets the demands of your application. Wherever possible, Modicon recommends that a multiconductor cable be considered, since it is inexpensive; it provides a backup in case a cable gets cut in the process of pulling it; and you will always find uses for the extra path(s), be it for voice, video, other communications, and/or other control applications.
- Most 62.5/125  $\mu\text{m}$  cables are rated at 3.5 dB loss per km. With a multiconductor cable, all the pairs usually come with an attenuation specification as measured, which may be significantly less than 3.5 dB/km.
- Most 9/125  $\mu\text{m}$  cables are rated at 0.45 dB loss per km.

## Hardware Overview

### Overview

This section provides detailed information about the requirements and availability of hardware components for the RIO cable system (see the table on the following page). Many of the components are available directly from Modicon; qualified alternative sources are also given.

### Required Coaxial Cable System Hardware Components

All RIO cable systems require the following hardware components:

- Taps to isolate the individual drop adapters from the rest of the network
- F connectors for making drop cable connections at the taps
- F or BNC connectors for making drop cable connections at the adapter
- Terminators to assure a properly balanced network and to keep unwanted signals out of the cable system

A splitter is required in a Hot Standby system to connect the primary and standby PLCs to the trunk cable, and may be used under certain conditions in other RIO cable topologies (see *Planning and Designing an RIO Cable System*, [page 19](#)).

### Optional Coaxial Cable System Hardware Components

Depending on the types of cable used in the system and on overall demands that will be placed on the network by the application, some of the following hardware options may be used in your RIO cable system:

- Adapters for converting from F to BNC connectors for making high performance semirigid trunk cable connections compatible with standard system hardware
- Self-terminating F adapters or in-line BNC terminators for automatic termination in drop cables should they be disconnected from the drop adapter

### Optional RIO Fiber Optics Repeater

The RIO Fiber Optics Repeater provides an alternative fiber-medium communication link between two or more RIO nodes or network segments. Each repeater contains one electrical RIO interface (an F-connector) and two fiber optic transceivers. The RIO interface has the same specifications and restrictions as a head RIO processor with a pre-amp—e.g., 35 dB dynamic range—and must be treated accordingly.

The 490NRP954 repeater is passive—i.e., there is no regeneration of the received signal in the repeater and no additional delay to the signal produced by the repeater.

The 140NRP95400 and 140NRP95401C repeaters are active—i.e., there is regeneration of the received signal in the repeater. The regeneration induce  $\sim 1\mu\text{s}$  additional delay to the signal produced by each repeater.



## RIO Coaxial Cable System Hardware Components

The following table shows the RIO coaxial cable system hardware components.

Description		Part Number
Tap		MA-0185-100
Splitter	Hot Standby system use	MA-0186-100
	used for trunk splitter	MA-0331-000
F Connectors	quad shield RG-11 (6/bag)	490RIO00211
	quad shield RG-6 (10/cassette)	MA-0329-001
Right angle F connector		52-0480-000
BNC connectors	non-quad shield RG-6	52-0487-000
	quad shield RG-6	043509446
F-to-BNC Adapter		52-0614-000
BNC Jack to male F connector		52-0724-000
Tap port terminator		52-0402-000
Trunk terminator		52-0422-000
BNC In-line terminator		60-0513-000
Self-terminating BNC Adapter	Hot Standby system and drop use	52-0370-000
Hot Standby Processor Warning Label	Hot Standby system use	MD-9423-000
Self-terminating F Adapter	Hot Standby system and drop use	52-0399-000 (non-quad shield RG-6)
	Hot Standby system and drop use	52-0411-000 (quad shield RG-6)
Ground block		60-0545-000
Surge suppressor		CBT-22300G (Relcom)
Semirigid Connectors	QR540JCA Cable	AI540FMQR (CommScope)
	QR869JCA Cable	AI860FMWQR (CommScope)

## Tap Specifications

### Overview

Modicon MA-0185-100 Taps connect the drop cables to the main trunk cable and isolate the RIO drop adapter from the rest of the network. This tap is nondirectional –it allows signals to be propagated in both directions along the trunk cable–. An MA-0185-100 tap has one drop port and two trunk ports.

**NOTE:** A Schneider Electric MA-0185-000 (PV:01) Tap may be supplied by your provider. It plays the same role as the legacy Modicon MA-0185-000 Tap and simply varies lightly in dimension and in the location of the earth ground connector (*see page 50*).

Tap dimensions:

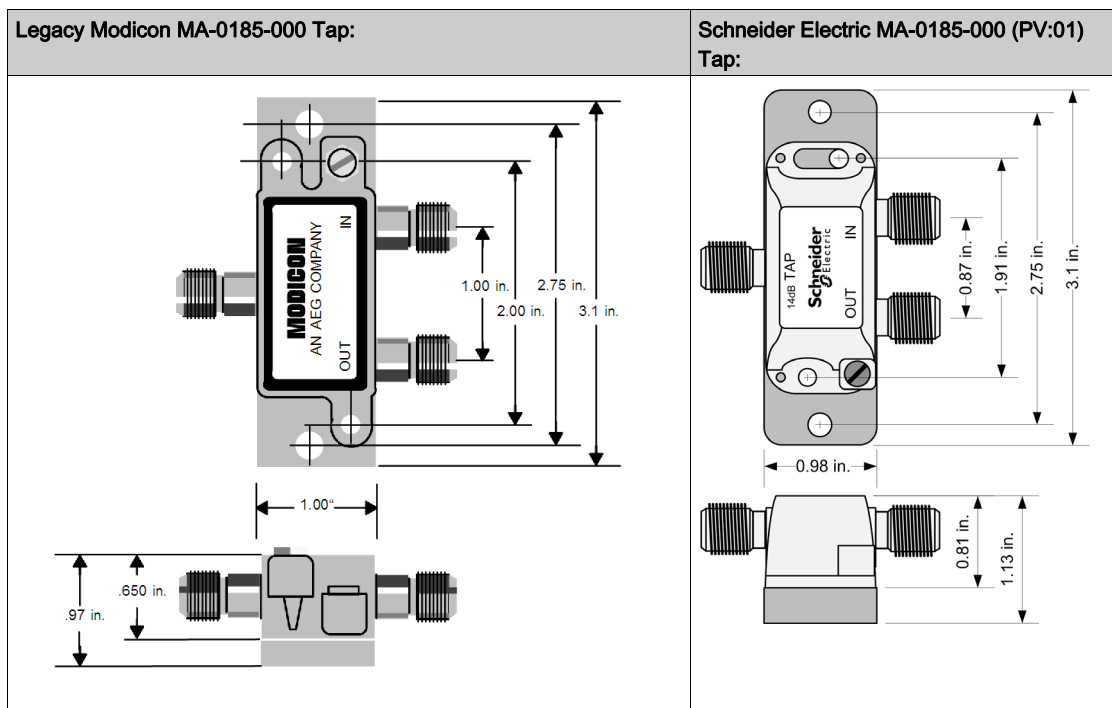

**NOTE:** Although the trunk ports are labeled IN and OUT, these labels can be ignored –it means that the tap is not directional–.

An MA-0185-100 tap is supplied with a plastic isolator on its back. The tap isolates the drop adapter from the trunk cable by 14 dB.

Unused ports on the taps must be terminated with a Modicon 52-0402-000 Port Terminator, and the last (trunk-out) port of the last tap on the network must be terminated with a Modicon 52-0422-000 Trunk Terminator (*see Network Terminators, page 83*).

The following table shows the specifications for the MA-0185-100 Tap.

<b>MA-0185-100 Tap Specifications</b>	
Impedance	75 $\Omega$
Frequency Range	100 kHz...30 MHz
Tap Loss	14 dB (+0.5 dB)
Trunk Insertion Loss	0.8 dB maximum
Trunk Return Loss	26 dB maximum
Tap Return Loss	-18 dB minimum
Temperature Range	-40...+60 °C
Humidity	95% at 85 °C
Sealing	RFI/EMI sealed
Cable Port Connections	Female F connectors. Required torque: 0.8...1.2 N.m (7.1...10.6 lbf-in).

## ***NOTICE***

### **INOPERABLE EQUIPMENT**

Do not tighten the F connector onto the cable port beyond specified torque.

**Failure to follow these instructions can result in equipment damage.**

**NOTE:** Taps not supplied by Modicon are not supported by Modicon.

**NOTE:** The Modicon MA-0185-000 Tap can be used on an RIO network if it is at Revision C. Do not use a lower revision of the MA-0185-000 tap.

**NOTE:** Do not ground a tap unless you are using it specifically as the single-point ground for the entire RIO cable system.

## Splitter Specifications

### Overview

The Modicon MA-0186-100 Splitter is used as a signal combiner in a Hot Standby cable system; each programmable controller has the ability to transmit onto the network using the splitter.

**NOTE:** A Schneider Electric MA-0186-100 (PV:01) Splitter may be supplied by your provider. It plays the same role as the legacy Modicon MA-0186-100 Splitter and simply varies lightly in dimension and in the location of the earth ground connector (*see page 50*).

The Modicon MA-0331-000 splitter is used as a branching device in certain trunk cable topologies, as defined in *Planning and Designing an RIO Cable System*, [page 19](#).

Modicon MA-0186-100 and MA-0331-000 Splitter dimensions:

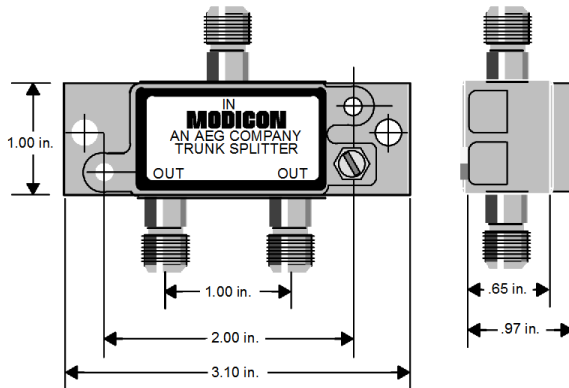

Schneider Electric MA-0186-100 (PV:01) Splitter dimensions:

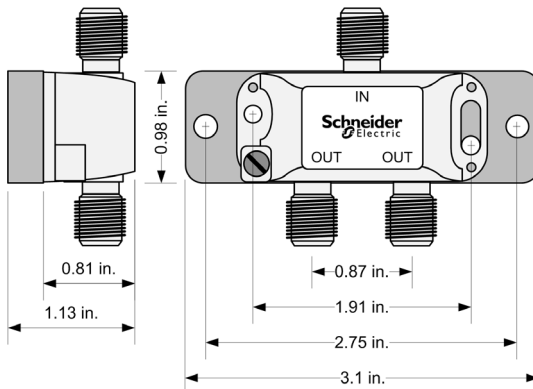

**NOTE:** When not in use, splitter ports must be terminated with a Modicon 52-0402-000 Port Terminator.

The following table shows the specifications for the MA-0186-100 and MA-0331-000 specifications.

	MA-0186-100	MA-0331-000
Impedance	75 $\Omega$	75 $\Omega$
Frequency Range	100 kHz...5 MHz	100 kHz...5 MHz
Trunk Insertion Loss	6.0 dB	3.5 dB
Trunk Return Loss	18 dB	30 dB
Temperature Range	-40 °C...+60 °C	-40 °C...+85 °C
Humidity	95% @ 60 °C	95% @ 85 °C
Sealing	RFI/EMI sealed	RFI/EMI sealed
Cable Port Connections	Female F connector. Required torque: 0.8...1.2 N.m (7.1...10.6 lbf-in).	Female F connector. Required torque: 0.8...1.2 N.m (7.1...10.6 lbf-in).

## ***NOTICE***

### **INOPERABLE EQUIPMENT**

Do not tighten the F connector onto the cable port beyond specified torque.

**Failure to follow these instructions can result in equipment damage.**

**NOTE:** Splitters not supplied by Modicon will not be supported by Modicon.

**NOTE:** The Modicon MA-0186-000 splitter can be used in an RIO network if the splitter is at least Revision B. Do not use a lower revision of the MA-0186-000 splitter.

**NOTE:** Existing systems that utilize the MA-0186-X00 as a trunk splitter are not required to upgrade to MA-0331-000 if performance is acceptable. The MA-0331-000 splitter provides higher port isolation.

## F Connectors for Coaxial Cables

### Overview

Flexible cables (RG-6 and RG-11) use F connectors to make the tap port connections; F connectors are also used to make the drop cable connection to certain drop adapters (see *Planning RIO Drops, page 61*). F connectors use a 3/8-32 thread. Always use industrial grade F connectors in RIO cable systems—commercial grade F connectors should not be used.

### F Connector for Quad Shield RG-6 Cable

The Modicon MA-0329-001 F Connector is recommended for quad shield RG-6 cable; it is packaged in a plastic cassette that contains ten connectors. These connectors can be purchased only by the cassette.

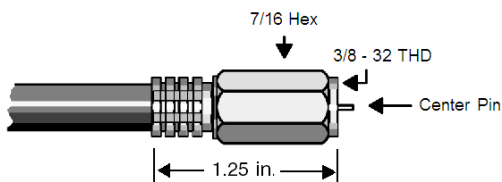

### F Connector for Quad Shield RG-11 Cable

The Modicon 490RIO00211 F connector is recommended for quad shield RG-11 cable; it is purchased in a package that contains six connectors.

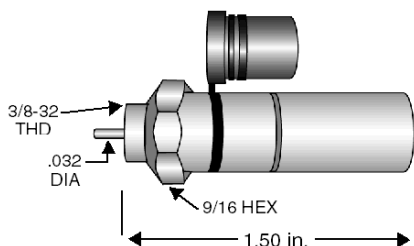

## F Connectors for Semirigid Cable

The following F connectors are suggested for use with CommScope® QR type semirigid cable. See *RIO Cable Material Suppliers*, page 153 for contact information.

The following illustration shows the Thomas & Betts LRC® two-piece AI540FMQR adaptor for connectorizing with QR 540 JCA cable.

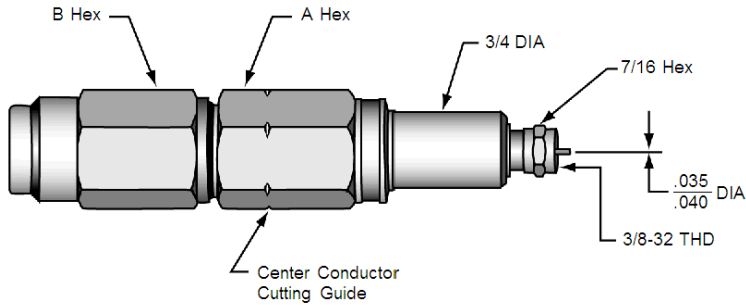

A Hex and B Hex = 1 in., Overall Length = 5 1/8 in.

The following illustration shows the Thomas & Betts LRC® three-piece AI860FMWQR adaptor for connectorizing with QR 860 JCA cable.

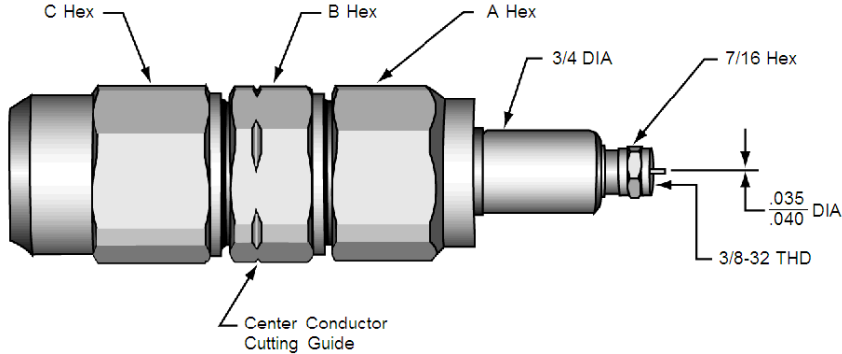

A Hex, B Hex and C Hex = 1 1/2 in., Overall Length = 5 5/8 in.

## F Adapters for Semirigid Cable

### Overview

A Modicon 52-0480-000 Right Angle F Adapter is usually needed to attach semi-rigid trunk cable to the F connector on a tap port; it may also be necessary at other connection points in order to maintain bend radius tolerance on a semirigid cable.

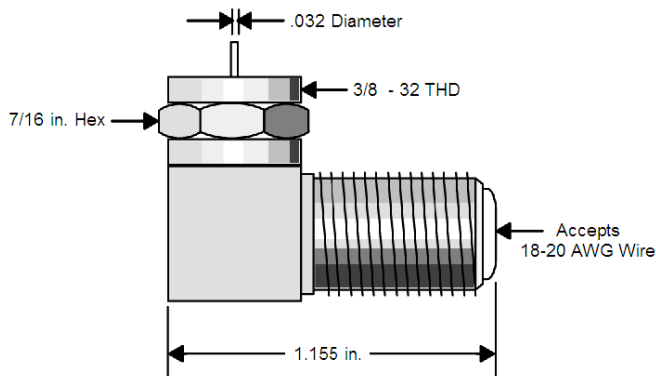

## ***NOTICE***

### **DESTRUCTION OF ADAPTER**

- Before tightening the locknut to the torque 0.46...0.60 N•m (4.1...5.3 lbf-in) be sure to properly position the right-angle F adapter connector.
- During tightening be sure to maintain the connector securely.
- The locknut must be loosened before handling the connector. For this reason, it is recommended to attach the S908 coaxial cable to the chassis to avoid any mechanical stress on the right-angle F adapter connector.
- Do not tighten the right-angle F adapter beyond the specified torque.

**Failure to follow these instructions can result in equipment damage.**



## BNC Connectors and Adapters

### Overview

Some drop cables may require a BNC connector to connect to certain RIO drop adapters (see *Planning RIO Drops, page 61*) or to certain RIO processors at the controller head-end. Always use industrial grade BNC connectors or adapters in RIO cable systems—commercial grade hardware should not be used.

### BNC Connectors for RG-6 Cable

The recommended BNC connectors fit RG-6 cable only. Two sizes of BNC connectors are available for quad shield and non-quad shield RG-6 cables:

- The Modicon 043509446 BNC Connector for quad shield (Consult Sales, available by special order only)
- The Modicon 52-0487-000 BNC Connector for non-quad shield cable

The following illustration shows the BNC Connector for RG-6 cable.

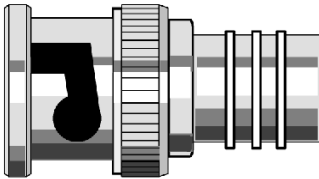

**NOTE:** Quad shield cable has a larger outside diameter, so it requires a larger connector. Do not use the wrong size BNC connector for the cable you are using. Belden flexible cables are the only approved non-quad shield cables.

### F-to-BNC Adapters for RG-11 Cable

There is no approved BNC connector for RG-11 cable. Where a BNC connection is required, use an approved F connector for the RG-11 cable followed by an adapter connection such as the Modicon 52-0614-000 F-to-BNC Adapter.

**NOTE:** The S901, S908, or S929 head processors used in the 984A, 984B, and 984X Programmable Controllers require the use of a 52-0614-000 F-to-BNC Adapter.

The following illustration shows the F-to-BNC Adapter.

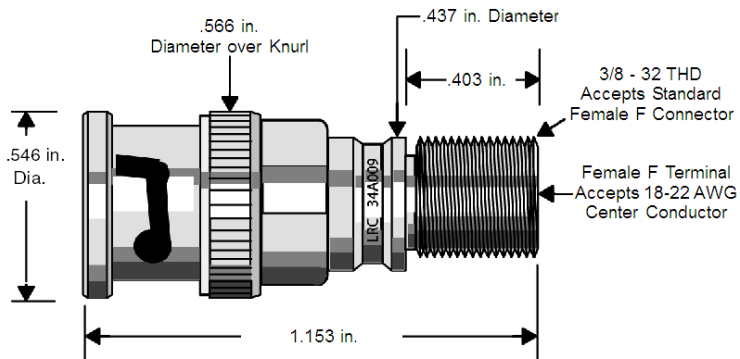

The 52-0614-000 Adapter permits the F connector on an RG-11 trunk cable to be attached to the BNC connector on an RIO processor at the network head-end or the F connector on an RG-11 drop cable to be connected to a J810/J812 or J890/J892 drop adapter at the drop.

### BNC Jack to Male F Connector

The 52-0724-000 Jack is supplied with the J890/J892-10x RIO drop adapters to terminate cables with BNC connectors. Consult Sales; this product is available by special order only.

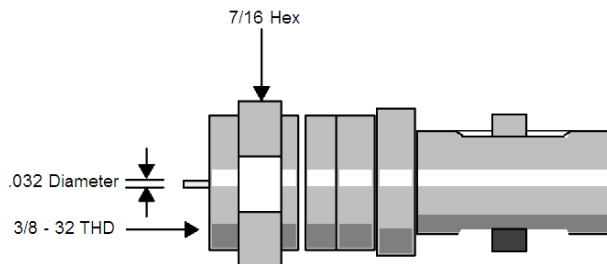

## Network Terminators

### Overview

All terminators used on the RIO network must have a power handling capability of at least 1/4 W. Terminators designed for power-handling, CATV applications, or broadband cable applications cannot be used on an RIO network—they do not work in the RIO frequency range and will cause signal distortion.

### Tap Port Terminators

All unused drop connectors on taps must be terminated with a standard 75  $\Omega$  tap port terminator. The Modicon 52-0402-000 Tap Port Terminator provides suitable termination for this purpose, with a return loss of 22 dB and a frequency range from 100 kHz ... 30 MHz.

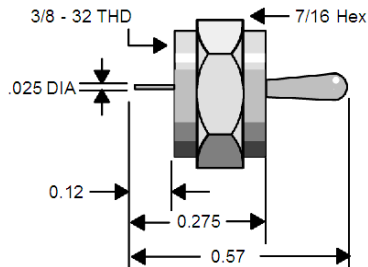

### Trunk Terminators

The trunk cable must be terminated at its tail-end point (in the trunk-out port of the last tap in the trunk cable) with a trunk terminator. The Modicon 52-0422-000 Trunk Terminator is a precision 75  $\Omega$ , 1% tolerance, 14 dB terminating resistor specifically designed for trunk termination. Do not use the 52-0402-000 Tap Port Terminator to terminate the trunk cable. The return loss of the 52-0422-000 Trunk Terminator is 40 dB or better at 10 MHz, and its frequency range is from 100 kHz ... 30 MHz.

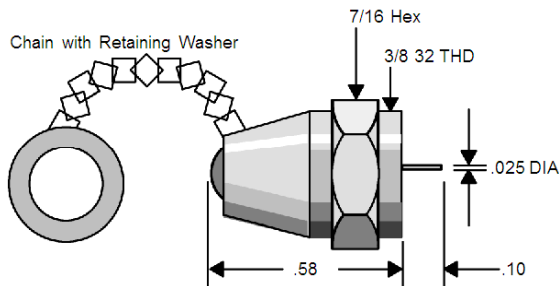

### BNC In-line Terminators

A Modicon 60-0513-000 BNC In-line Terminator is used to terminate the end of a drop cable for nodes that require external 75 Ω termination with BNC-type connections—i.e., the older J890/J892-00x Adapters and the Modicon 410 and 3240 Motion products (see the list in *RIO Network Cable System*, page 16).

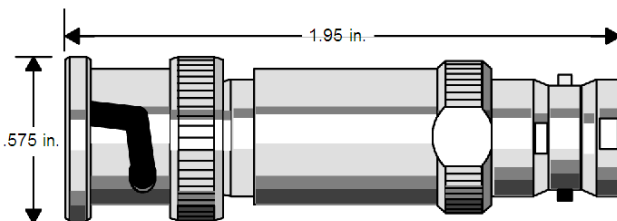

The 60-0513-000 In-line Terminator has two BNC connectors—a female for the incoming drop cable and a male to connect to the drop adapter. It has a return loss of 20 dB (VSWR 1.2:1), a frequency range from DC ... 300 MHz, and an insertion loss of 0.03 dB.

### Self-terminating BNC Adapters for Hot Standby Systems and Drop Cables

Modicon 52-0370-000 Self-terminating BNC Adapters are used in 984 Hot Standby systems and on drop cables. They allow one Hot Standby PLC to be disconnected from the network without causing open-circuit communications errors in the other PLC. Used on the end of a drop cable, they maintain proper termination when an RIO drop is removed from the network. One side of the terminator has a female F connector, and the other side has a female BNC connector. The adapter stays on the cable active side and only the BNC side should be disconnected while the network is operating. Disconnecting the F connection side will cause an impedance mismatch on the trunk.

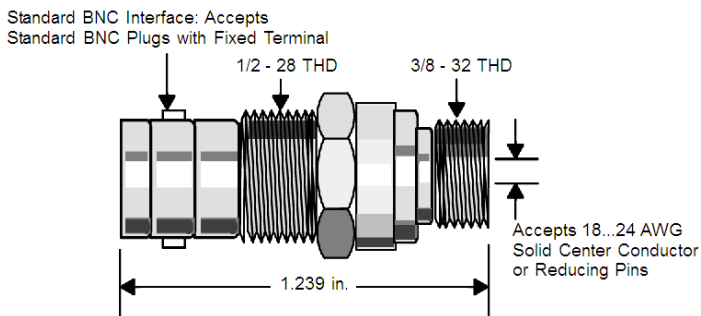

The 52-0370-000 Self-terminating BNC Adapter has a return loss of 40 dB, a frequency range from 100 kHz ... 30 MHz, and an insertion loss of 0.03 dB.

## Self-terminating F Adapter Options

### Self-terminating F Adapters for RG-6 Hot Standby Systems and Drop Cables

The 75  $\Omega$  self-terminating F adapters (STFA) crimp onto the RG-6 cable. There are two types of self-terminating F adapters:

A Modicon 52-0411-000 model for quad shield cable

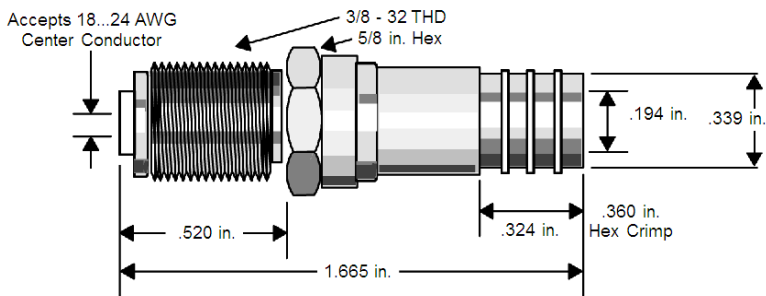

A Modicon 52-0399-000 model for non-quad shield cable

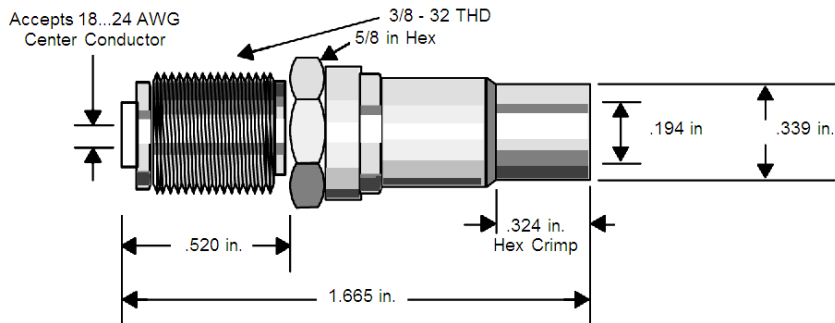

Both of these self-terminating F adapters have a return loss of 22 dB, a frequency range from 100 kHz ... 30 MHz, and an insertion loss of 0.03 dB.

If you are using RG-11 cable, these crimp-on self-terminating F adapters cannot be used. For RG-11 drop cables, use the 52-0370-000 F to BNC Self Terminator and a 52-0164-000 BNC to F Adapter.

### Warning Labels

The self-terminating BNC adapters require warning labels, which promote proper connection and disconnection practices. Modicon MD-9423-000 Hot Standby Processor Warning Labels wrap around the cable near the self-terminating BNC adapters; connect/disconnect instructions are provided on both sides of the label.

## Ground Blocks

### Overview

A cable system must be grounded at all times to assure safety and proper operation of the nodes on the network. The RIO head processor grounds the cable system, but if the cable is disconnected, that earth ground connection is removed. An optional Modicon 60-0545-000 Ground Block at the head will provide earth ground connection when the cable and RIO processor are disconnected. Ground blocks may also be used at other ground points along the trunk cable, as required.

**NOTE:** Local building codes may require that the cable shield be tied to earth ground whenever the cable system exits and/or enters a new building (NEC Article 820-33).

Ground blocks have a low insertion loss, and they usually are not figured into the attenuation calculations unless five or more are used—in that case, calculate an extra .2 dB into the trunk attenuation. The ground block has a 75  $\Omega$  impedance, a return loss of >40 dB, and a wide application frequency range. The 60-0545-000 Ground Block consists of two female in-line F connectors and a separate screw hole binding for attaching a ground wire. The grounding block has two mounting holes, allowing it to be mounted to a flat surface.

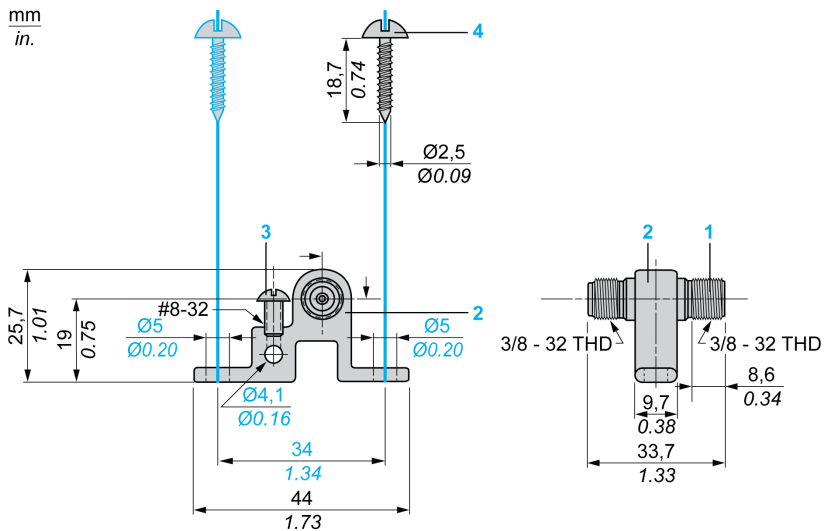

- 1 Female in-line F connector
- 2 Grounding block
- 3 Locking screw (for ground wire)
- 4 Mounting screw

## Surge Suppressors

### Overview

Surge protection is available for coaxial network trunks that span between buildings and are exposed to lightning. The recommended product has internal gas discharge surge protectors that absorb very high currents induced into the cable system by near-lightning strikes. The device indicated has insertion loss of less than 0.3 dB at the network operating frequency. The unused drop ports must be terminated with a Modicon 52-0402-000 Port Terminator. If desired, shrink tubing may be used to seal the F connections.

The device should be accessible for maintenance, and be protected from the elements if installed outside. The threaded stud should be connected to building ground.

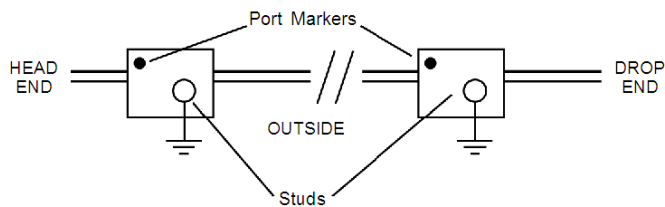

The recommended product is Relcom Inc. Part Number CBT-22300G.

See *RIO Cable Material Suppliers*, [page 153](#) for contact information.



The following diagram shows the surge suppressor.

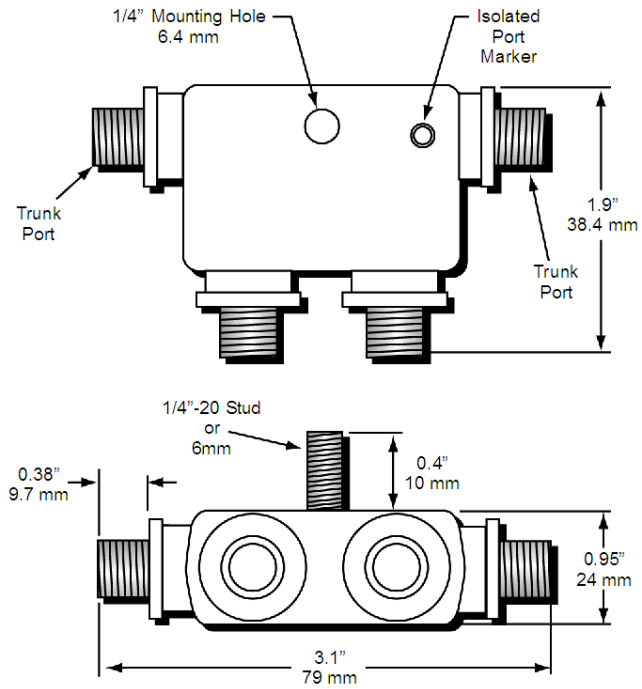

## 140NRP95400 and 140NRP95401C Fiber Optic Repeater Modules

### Overview

The 140NRP95400 and 140NRP95401C fiber optical repeater modules provide communication between two or more RIO nodes or segments of networks over a fiber optic medium. Each repeater contains one electrical RIO interface and two fiber optic transceivers.

### 140NRP95400 Module Description

The following figure shows the 140NRP95400 multimode fiber optic repeater module parts:

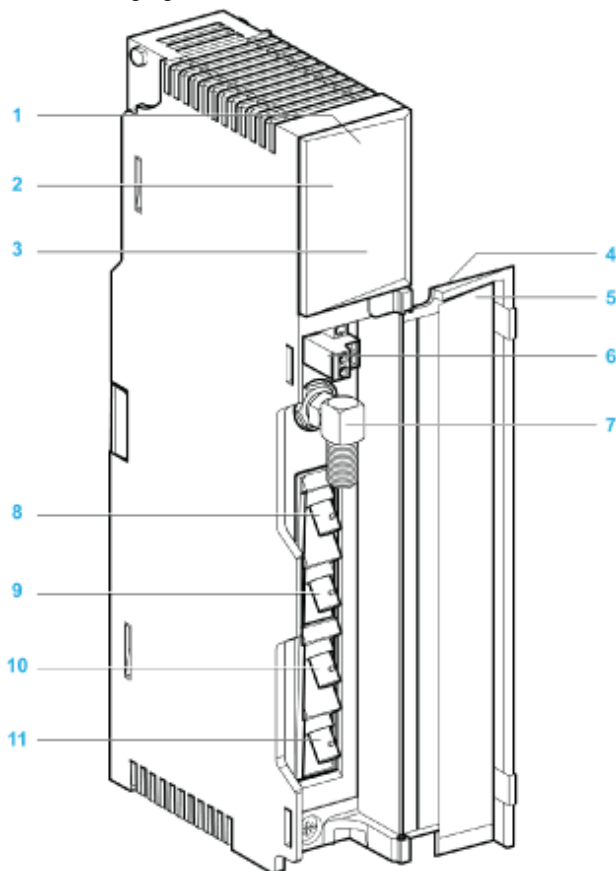

- 1 Version label
- 2 Model number, module description, color code
- 3 LED area
- 4 Removable door
- 5 Customer identification label (Fold label and place it inside door)

- 6 Diagnostic relay port
- 7 Electrical coaxial port ("F" type connector)
- 8 Transmitter optical fiber port - FPort 1 Tx (ST type connector)
- 9 Receiver optical fiber port - FPort 1 Rx (ST type connector)
- 10 Receiver optical fiber port - FPort 2 Rx (ST type connector)
- 11 Transmitter optical fiber port - FPort2 Tx (ST type connector)

### 140NRP95401C Module Description

The following figure shows the 140NRP95401C single-mode fiber optic repeater module parts:

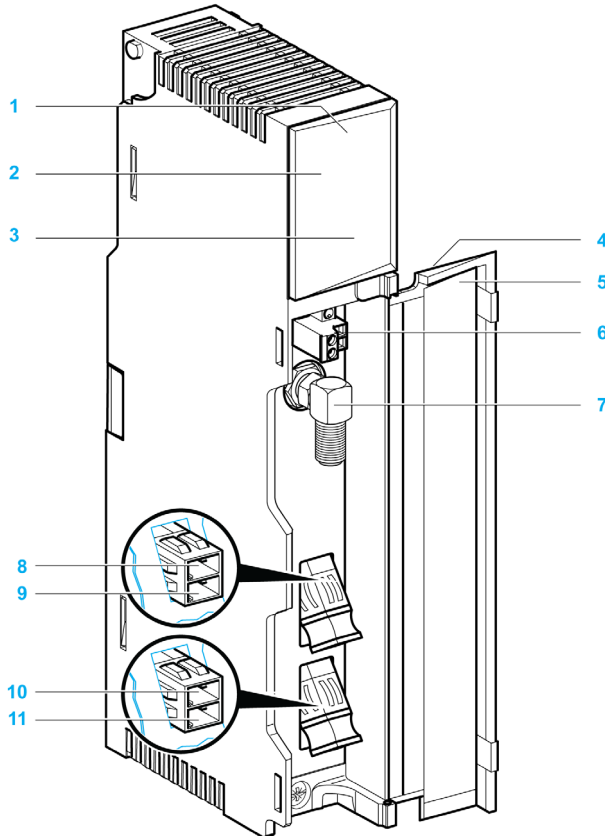

- 1 Version label
- 2 Model number, module description, color code
- 3 LED area
- 4 Removable door
- 5 Customer identification label (Fold label and place it inside door)
- 6 Diagnostic relay port
- 7 Electrical coaxial port ("F" type connector)
- 8 Receiver optical fiber port - FPort 1 Rx (LC type connector)
- 9 Transmitter optical fiber port - FPort 1 Tx (LC type connector)
- 10 Receiver optical fiber port - FPort 2 Rx (LC type connector)
- 11 Transmitter optical fiber port - FPort2 Tx (LC type connector)

- 9 Transmitter optical fiber port - FPort 1 Tx (LC type connector)
- 10 Receiver optical fiber port - FPort 2 Rx (LC type connector)
- 11 Transmitter optical fiber port - FPort 2 Tx (LC type connector)

### Related Document

See the *Modicon 140 NRP 954 00 and 140 NRP 954 01C Fiber Optic Repeater Modules User Guide* for more detailed information.

### Repeater Indicator LEDs

The following figure shows the LED indicators for the fiber optic repeater module:

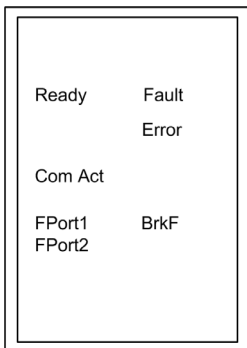

The following table describes the status LEDs of the module:

LED	Color	State	Indication
Ready	Green	OFF	The module is unpowered or the internal logic is out of order.
		ON	The module is powered and the internal logic is available.
ComAct	Green	OFF	No activity on the coaxial cable.
		ON	Activity is detected on the coaxial cable.
FPort1	Green	OFF	No activity on the optical fiber port 1 reception.
		ON	Activity is detected on the fiber port 1 reception.
FPort2	Green	OFF	No activity on the optical fiber port 2 reception.
		ON	Activity is detected on the fiber port 2 reception.
Fault	Red	OFF	No error (internal or external) detected.
		ON	An error (internal or external) has been detected.
Error	Red	OFF	No internal error detected.
		ON	An internal error has been detected.

LED	Color	State	Indication
BrkF	Red	OFF	Activity is detected on both optical port inputs OR no activity has ever been detected on any optical port input.
		ON	One of the optical fiber port input is inactive (see FPort• LED OFF) while activity is detected or has been detected on the other optical port input (see FPort• LED ON).

### Diagnostic Relay Behavior

A normally closed relay contact, rated at 220 Vac 6 A or 30 Vdc 5 A, is available on the terminals of the diagnostic relay port via its connector.

The contacts of the relay are open whenever an error is detected (internal or external), and the Fault LED is ON. In fact the status of the diagnostic relay provides an electric information when the Fault LED status provides a visual status when an error is detected (internal or external).

Furthermore when the contacts of the diagnostic relay are open,

- if the detected error is internal the Error LED is ON.
- if the detected error is external the BrkF LED is ON.

**NOTE:** When the module is not powered, the contacts of the diagnostic relay are open.

### RIO Shield-to-Chassis

The shield of the coaxial cable of the fiber optic repeater module is directly tied to the backplane.

A cable system must be grounded at all times to ensure safety for the personnel and proper operation of the nodes on the network. If the RIO cable is removed from the fiber optic repeater module, as the ground connection to the backplane is linked to the RIO cable, the ground connection does not exist anymore. An optional Modicon 60-0545-000 ground block (*see page 87*) provides earth ground connection.

### Backplane Integration

Instead of placing each fiber optic repeater modules with its own power supply module(s) in a standalone backplane, you can take the advantage of the quantum form factor.

The following figure shows two segments of RIO coaxial cable connected point-to-point by two fiber optic repeaters placed on the Quantum racks where the RIO head and RIO drop modules are located:

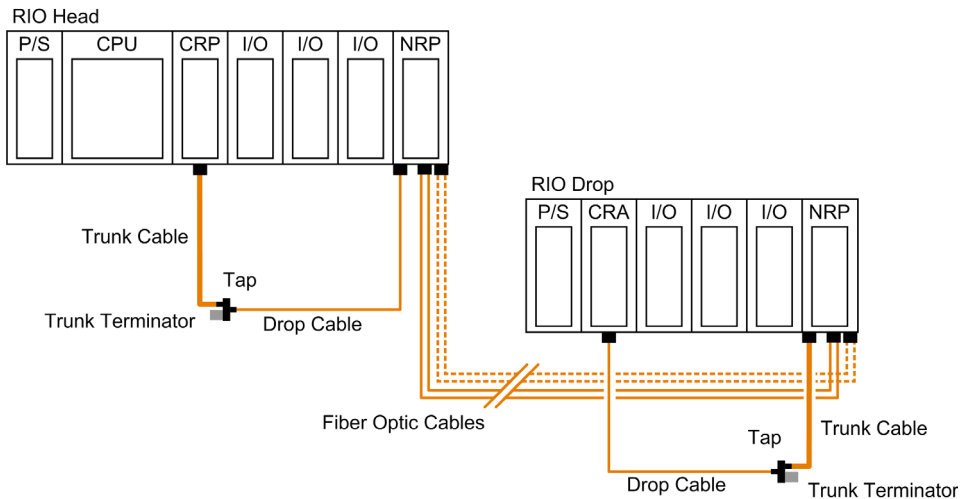

## 490NRP954 Fiber Optic Repeater

### Overview

The 490NRP954 Fiber Optic Repeater provides communication between two or more RIO nodes or segments of networks over the fiber optic medium. Each repeater contains one electrical RIO interface and two fiber optic transceivers.

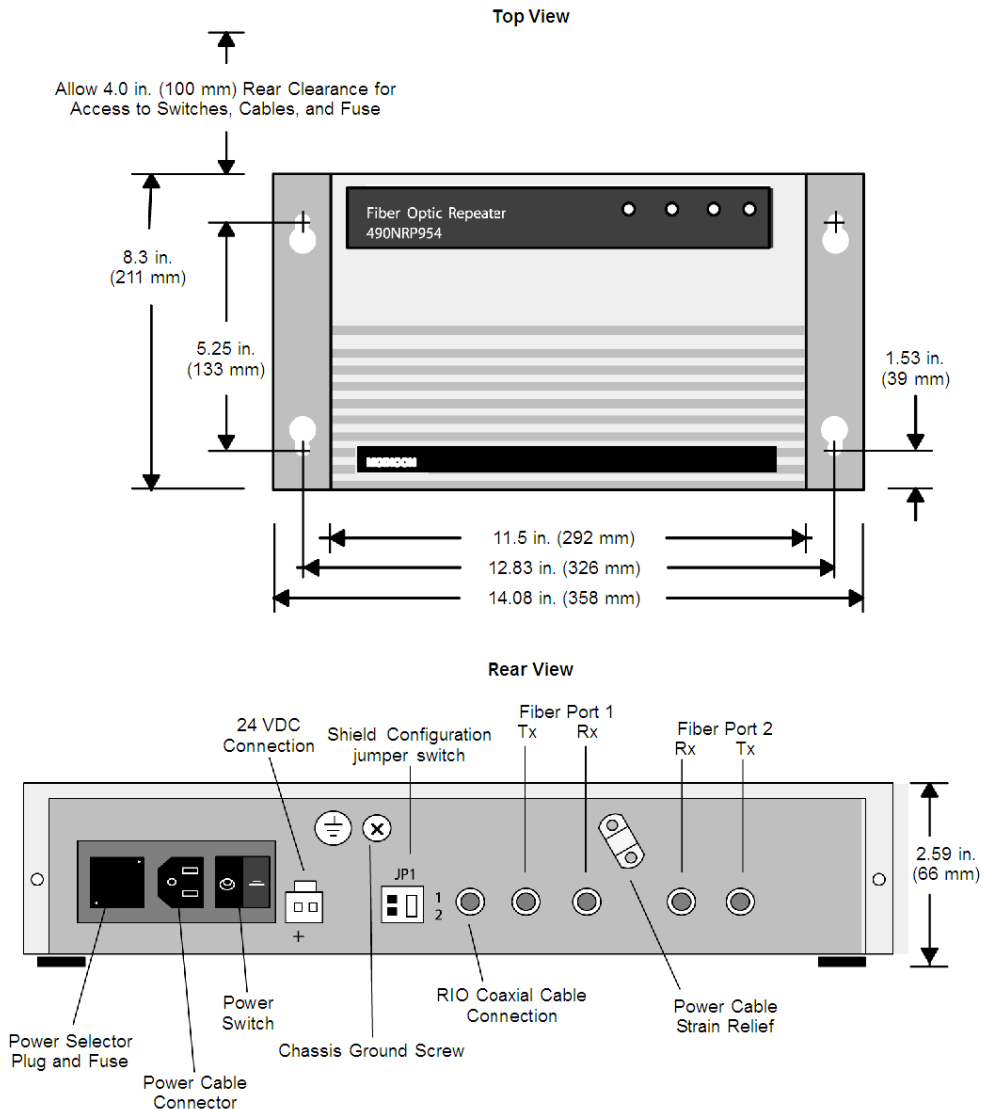

## Related Documentation

See the *Modicon Fiber Optic Repeaters User's Guide*, part number GM-FIBR-OPT, for more detailed information.

## Repeater Indicator LEDs

The repeater has a set of LEDs located on the top of the unit:



- The **power ok** LED illuminates steadily when the Repeater has normal power from the AC line or DC source and its internal power supply is operating normally
- The **remote I/O** port LED lights when a signal is received at the RIO port
- Each **fiber port** LED lights when a signal is received at the fiber Rx port

If a port LED fails to illuminate, it can indicate a lack of transmitted signal at another network node. Before replacing a repeater, check the cable connections on the rear panel for a possible incorrect or loose connection. Also check the indicators on other devices on the signal path to see if the signal loss is external to the repeater.

## RIO Shield-to-Chassis Jumper

The RIO cable shield-to-chassis jumper switch on the rear of the repeater is used to specify the repeater's relationship to chassis ground.

RIO cable shield must be set to specify the NRP relationship to chassis ground. Jumper switch is shipped in neutral position as indicated on the picture below:

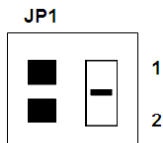

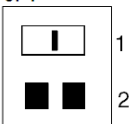
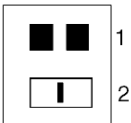

It have to be placed :

Switch position	Function
1	<p>NRP acts as a drop on CRP side (RIO cable shield is isolated from chassis ground by a capacitor) -i.e if low frequency is a problem.</p> <p><b>JP1</b></p> 
2	<p>NRP acts as a head on CRA side (RIO cable shield is connected directly to chassis ground) - i.e. the same ground as the main RIO head.</p> <p><b>JP1</b></p> 

In a point-to-point optical connection, one repeater is always the head and the other is always the drop:

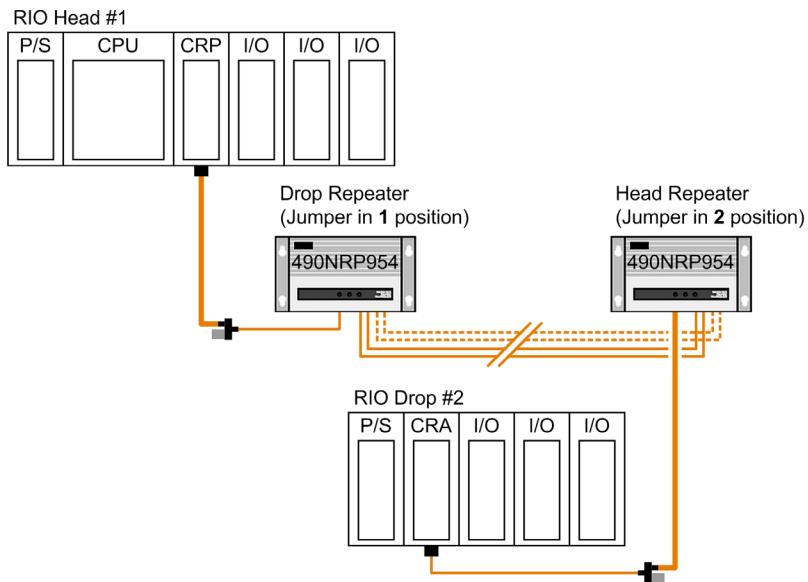

In an optical bus connection, one repeater is always the drop and all other repeaters are heads:

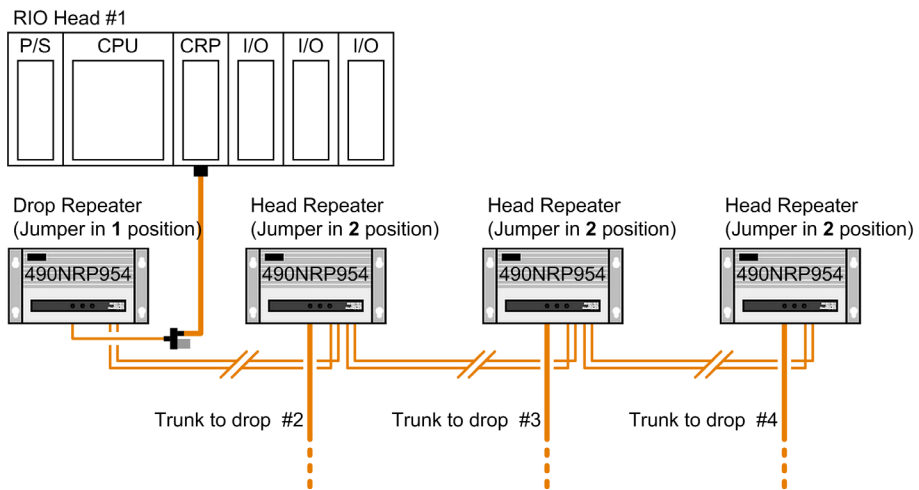

## Recommended Materials for Multimode Fiber Optic Links

### Overview

Modicon does not manufacture fiber optic products such as cables, connectors, or special tools. However, we have experience with third party suppliers of materials and can provide some guidelines on what will work with our products.

### Connectors

The following table shows recommended connectors.

Connector Type	Part Number	Operating Temperature
ST Bayonet (Epoxy)	3M 6105	-40...+80 °C (-40...+176 °F)
ST Bayonet (Hot Melt)	3M 6100	-40...+80 °C (-40...+176 °F)
ST Bayonet (Epoxy)	AMP 501380 Series	-30...+70 °C (-22...+158 °F)
ST Cleave and Crimp	AMP 504034 Series	-40...+65 °C (-40...+149 °F)
Mechanical Line Splice (one size fits all)	3M 2529 Fiberlok™ II	-40...+80 °C (-40...+176 °F)

### Termination Kits

The following table indicates recommended termination kits.

Kit Type	Part Number	Description
Bayonet or Push-Pull ST (Hot Melt)	3M 6355	110 Vac, only for 3M connectors
Bayonet ST (Epoxy)	AMP 501258-7	110 Vac, only for AMP connectors
Bayonet ST (Epoxy)	AMP 501258-8	220 Vac, only for AMP connectors
Mechanical Line Splice	3M 2530	Fiber Splice Prep Kit, complete with cleaving tool

### Light Sources, Power Meters

For Photodyne light sources and power meter products, contact 3M Telecom Systems Division. See RIO Cable Material Suppliers ([see page 153](#)) for contact information.



---

# Chapter 4

## Installing an RIO Network

---

### Overview

This chapter provides information on installing an RIO network.

### What Is in This Chapter?

This chapter contains the following topics:

Topic	Page
Installation Overview	102
RG-6 Cable Connections	103
RG-6 Cable Installation Tool	104
Preparing RG-6 Cable for a Connector	106
Installing F Connectors on Quad Shield RG-6 Cable	108
Installing BNC or Self-terminating F Connectors on RG-6 Cable	111
RG-11 Cable Connections	113
The RG-11 Installation Tool	114
Installing F Connectors on RG-11 Cable	115
Semirigid Cable Connections	119
Semirigid Cable Installation Tools	120
Preparing a Semirigid Cable for a Connector	121
Installing F Connectors on Semirigid Cable	122
Semirigid Trunk Cable Tap Port Connections	123
Providing Line Termination on the Drop Cable	124
Connecting/Disconnecting a Drop Cable at a Tap	126
Installing 140NRP95400 and 140NRP95401C Fiber Optic Repeater Modules	128
Installing 490NRP954 Fiber Optic Repeaters	133
Terminating the Trunk Cable	137
Installing the Ground Point	138

## Installation Overview

### Overview

This chapter presents cable preparation and installation procedures for coaxial cables. Many connectors and special-purpose installation tools required for these cables are available from Modicon.

Modicon provides a common family of compatible connectors for RG-6 and RG-11 cables. A set of installation procedures has been established, with a common set-up procedure and separate finishing procedures for each type of connector used. Information is provided for semirigid cable preparation and installation and for fiber repeater installation.

### Related Documentation

See the *Modicon 140NRP95400 Fiber Optic Repeater Module User Guide*, for more detailed information on the 140NRP95400 repeater.

See the *Modicon Fiber Optic Repeaters User's Guide*, part number GM-FIBR-OPT, for more detailed information on the 490NRP954 repeater.

## RG-6 Cable Connections

### Overview

Connectors available for RG-6 cable are:

Connector	Type	Cable Design	Crimp Size
MA-0329-001	F	Quad	.360
52-0487-000	BNC	Non-quad	.324
043509446	BNC	Quad	.360
52-0399-000	Self-terminating F	Non-quad	.324
52-0411-000	Self-terminating F	Quad	.360

### Installation Tools

Tools required for RG-6 connectors are:

- Modicon 60-0558-000 Cable Cutters
- Modicon 490RIO00400 RG-6 Installation Tool with blade pack
- Modicon 60-0544-000 Crimp Tool for quad shield F connectors
- Modicon 043509432 Crimp Tool for BNC connectors
- A standard 7/16 in. open-end wrench
- Modicon 60-0544-000 Crimp Tool

**NOTE:** If you purchase premade drop cables from Modicon, you may not need the Modicon RG-6 installation tool or the crimp tool for installation purposes, but we recommend that you have it for maintenance.

## RG-6 Cable Installation Tool

### RG-6 Cable Installation Tool

A Modicon 490RIO00400 RG-6 Installation Tool is used to strip RG-6 cable for installation of F connectors. There are two blades in an installation tool insert. The first is designed to cut through the cable to the center conductor, cutting away the jacket, the shields, and the dielectric. The second blade is designed to cut off only the jacket, leaving as much braid as possible under it.

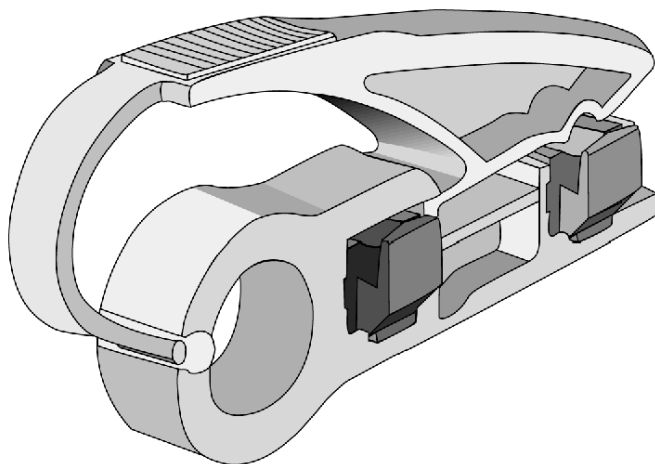

### Replacement Blade Packs

The blades on the RG-6 installation tool get dull after several hundred uses. A Modicon 490RIO00406 Replacement Blade Pack is available.

### Crimp Tools

The Modicon 60-0544-000 Crimp Tool is used to install the quad shield F connectors and self-terminating F adapters onto RG-6 cable. The tool makes two sizes of hex crimp: 0.324 in. and 0.360 in. Use 0.360 in. for the F Connector.

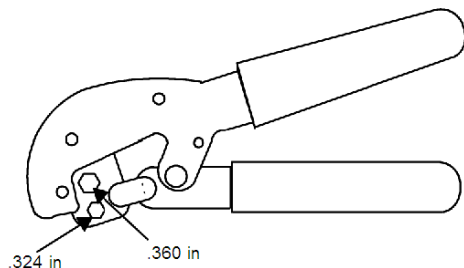



The Modicon 043509432 Crimp Tool is used to install BNC connectors onto RG-6 cable. The tool makes two sizes of hex crimp: 0.276 in. and 0.325 in. Consult Sales, available by special order only.

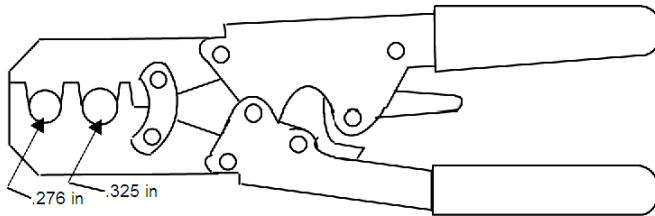

### Cable Cutters



Modicon 60-0558-000 Cable Cutters are used to cut cable without compressing it. The cable cutters have a high leverage handle and rounded cutting edges. Cable cut with normal flat diagonal cutters will flatten, and this will alter the cable's impedance.



## Preparing RG-6 Cable for a Connector

### How to Prepare an RG-6 Cable for a Connector

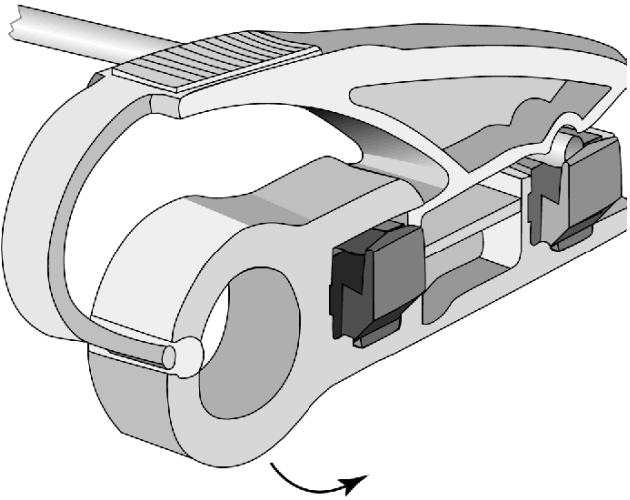
The following procedure shows you how to prepare the RG-6 cable for a connector.

Step	Action
1	<p>Cut the cable squarely across the end with the 60-0558-000 Cable Cutters. Open the jaws of the 490RIO00400 RG-6 Installation Tool and set the cable in the trough with the cable end placed against the stop.</p> 
2	<p>Release the handle and let the spring hold the tool on the cable. Rotate the stripper with your index finger on the handle until the tool turns freely. Let the spring provide the cutting pressure. Note: Adjust the number of rotations so that the second blade cuts as little of the braid as possible. When the crackling noise stops, the first blade has cut through the shields.</p>
3	<p>If the cable is not fully stripped, you may squeeze the jaws of the tool together with your thumb and forefinger. Using light pressure, make one or two revolutions of the tool around the cable until the tool cuts through the cable jacket.</p>
4	<p>Open the jaws and remove the cable. Twist off the cable dielectric and jacket by hand. Remove any long braid strands remaining around the prepared cable end. (Long braid strands may indicate that a new blade pack is needed.) Remove any dielectric on the exposed center conductor.</p> 

Step	Action
5	 <ol style="list-style-type: none"><li data-bbox="353 326 724 350">1 Fold all of the braid over the jacket.</li><li data-bbox="353 354 701 378">2 Avoid tearing the inner cable foil.</li></ol> <p data-bbox="353 402 1240 448">Once this cable preparation procedure is completed, you are ready to install RG-6 connectors and/or adapters on the cable.</p>

## Installing F Connectors on Quad Shield RG-6 Cable

### Overview

The following steps describe how to install F connectors on quad shield RG-6 cable.

**NOTE:** Use an F Connector from an MA-0329-001 Cassette on an RG-6 quad shield cable prepared according to the procedure described in Preparing RG-6 Cable for a Connector (*see page 106*).

### Installing F Connectors

The following steps demonstrate how to install F connectors.

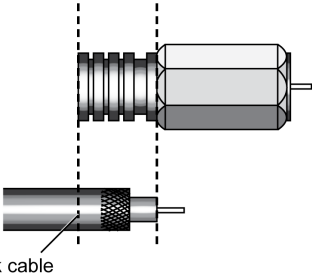
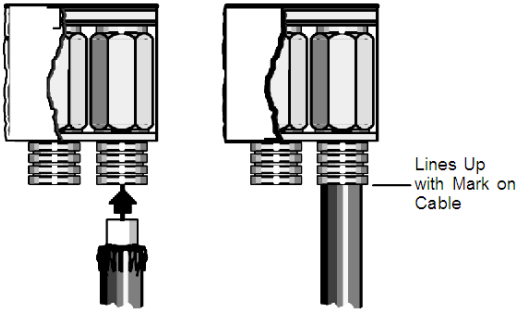
Step	Action
1	<p>Place the cable against the side of an F connector, aligning the end of the jacket with the bottom of the crimp ring. Mark the cable jacket at the top of the crimp ring.</p> 
2	<p>Using a twisting motion, push the cable firmly into the end of the F connector in the MA-0329-001 Cassette until the cable mark lines up with the end of the crimp ring.</p> 

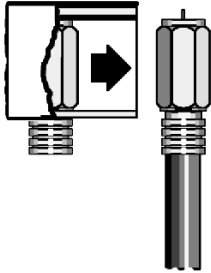
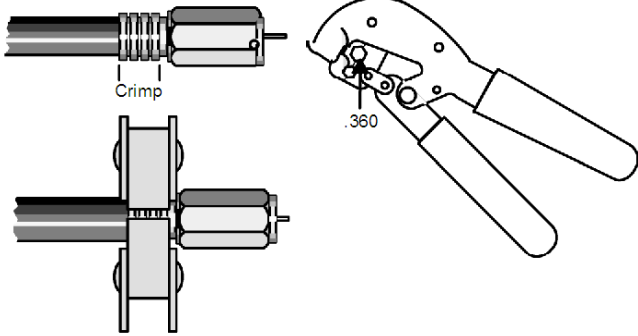
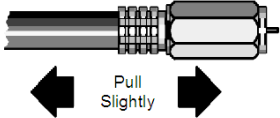
Step	Action
3	<p data-bbox="351 203 965 227">Remove the F connector by sliding it out the side of the cassette.</p> 
4	<p data-bbox="351 600 1100 625">Align the 60-0544-000 Crimp Tool on the F connector, and apply a .360 in. crimp.</p> 
5	<p data-bbox="351 1031 1064 1079">Pull on the F connector to make sure that the crimp is snug—the connector should not fall off.</p> 

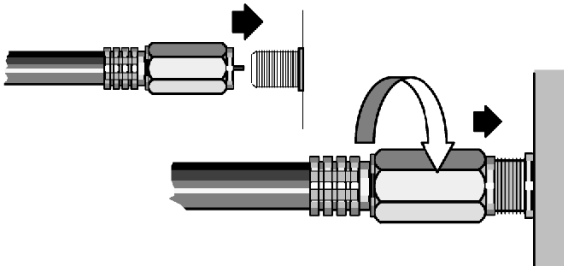
Step	Action
6	<p>Install the F connector onto the cable port of the RIO drop adapter, tap, or other cable hardware device using a 7/16 in. open-end wrench.</p>  <p><b>Note:</b> Finger tightening is not sufficient. Required torque is: 0.8...1.2 N•m (7.1...10.6 lbf-in).</p>

## ***NOTICE***

### **INOPERABLE EQUIPMENT**

Do not tighten the F connector onto the cable port beyond specified torque.

**Failure to follow these instructions can result in equipment damage.**

## Installing BNC or Self-terminating F Connectors on RG-6 Cable

### Overview

The following procedure may be used to install either a BNC connector or a self-terminating F adapter on an RG-6 cable. The BNC connector and self-terminating F adapter are available in two versions that fit non-quad shield and quad shield cable. Make sure that you are using the proper size connector for the cable.

Connector Type	Cable Type	Connector Part #	Crimp Size
BNC	Non-quad	52-0487-000	0.324
BNC	Quad	043509446	0.360
Self-terminating F	Non-quad	52-0399-000	0.324
Self-terminating F	Quad	52-0411-000	0.360

### Installing BNC Connectors

Take the following steps to install BNC or self-terminating F connectors.

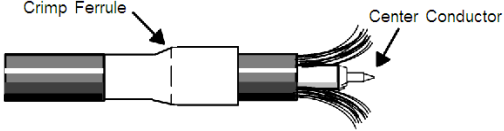
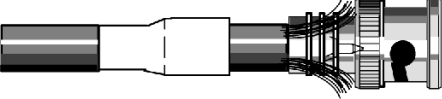
Step	Action
1	<p>Strip the end of the cable jacket by a maximum of 0.375 in. and gently flare the cable shield, exposing the cable's center conductor. Slip a crimp ferrule onto the cable as shown below.</p>  <p>The diagram shows a cross-section of an RG-6 cable. The outer jacket has been stripped back, and the shield is flared. A crimp ferrule is being slid onto the cable. Labels with arrows point to the 'Crimp Ferrule' and the 'Center Conductor'.</p>
2	<p>Insert the cable center conductor into the stem of the connector, pushing firmly to enter the spring clip of the pin. The cable insulator should seat on the connector insulator. Distribute the cable shield evenly around the outside of the connector collar.</p>  <p>The diagram shows the cable from step 1 being inserted into a connector. The center conductor is being pushed into the stem of the connector, and the shield is being distributed around the collar.</p>

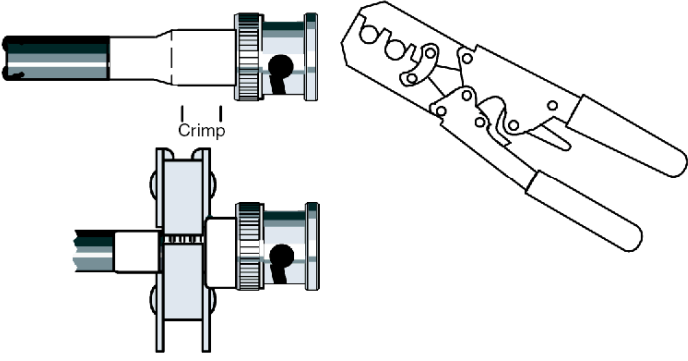
Step	Action
3	<p>Work the ferrule over the shield braid onto the connector collar. Then crimp with the 043509432 tool.</p> 

### Installing Self-Terminating Crimp-on Connectors

The RG-6 Self Terminating Crimp-on Connectors are prepared the same way as the MA-0329-000 connectors. Use the appropriate 60-0544-000 tool crimp die.



## RG-11 Cable Connections

### Overview

To make a connection to an RG-11 cable, use a 490RIO00211 F connector from Modicon.

### Required Tools

The following tools are required to install an F connector on an RG-11 cable:

- the Modicon 490RIO0S411 RG-11 Installation Tool with gray blade pack
- the Modicon 490RIO0C411 Connector Installation Tool
- the Modicon 60-0558-000 Cable Cutters (see *RG-6 Cable Installation Tool*, [page 104](#))
- a standard 9/16 in. open-end wrench

## The RG-11 Installation Tool

### Overview

The Modicon 490RIO0S411 is used to strip RG-11 cable for installation of F connectors. There are two blades in an installation tool insert. The first blade is designed to cut through the cable to the center conductor, cutting away the jacket, the shields, and the dielectric. The second blade is designed to cut off only the jacket leaving as much braid as possible under it.

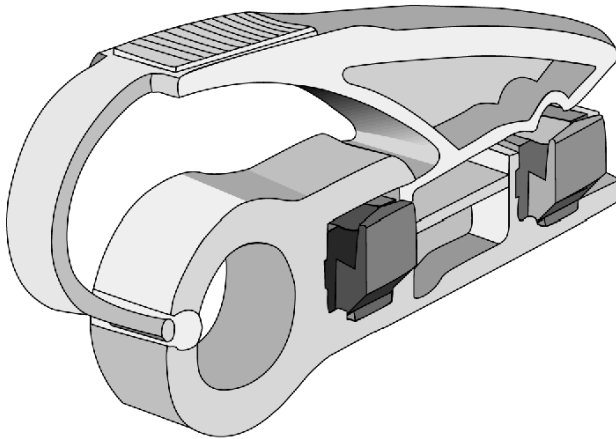

### Replacement Blade Packs

The blades on the RG-11 installation tool get dull after several hundred uses. A Modicon 490RIO00411 Replacement Blade Pack is available.

## Installing F Connectors on RG-11 Cable

### Overview

**NOTE:** Use a 490RIO002111 F connector and prepare the cable according to the procedure described below.

### Installing F Connectors

The following steps demonstrate how to install F connectors.

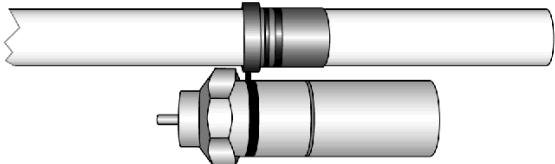
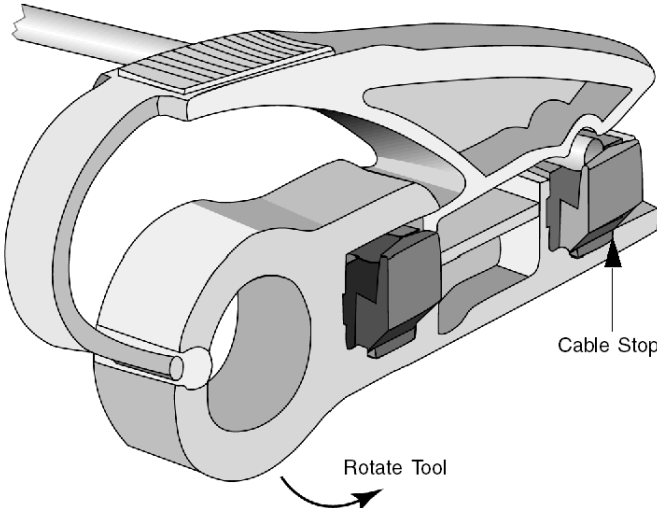
Step	Action
1	Cut the cable squarely across the end with the 60-0558-000 Cable Cutters.
2	Slide connector assembly over the cable as shown. 
3	Open the jaws of the 490RIO0S411 Installation tool and set the cable in the trough with the cable end placed lightly against the cable stop 

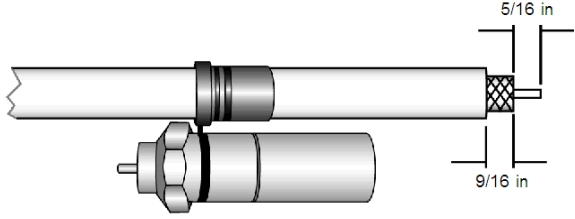
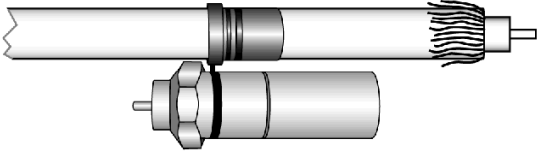
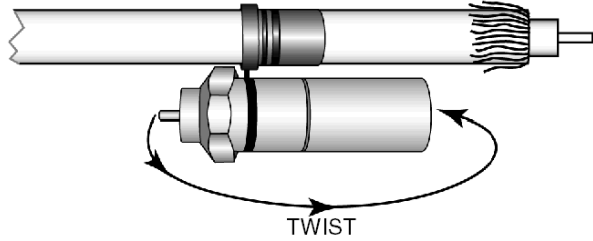
Step	Action
4	<p>Release the tool handle and let the spring hold the tool on the cable. Slowly rotate the tool 8 to 12 turns (as shown above) or until the tool turns freely. Let the spring provide the cutting pressure. Pull the tool from the cable to complete the cable prep.</p>
5	<p>Cable end should appear as shown.</p> 
6	<p>If using single braid cables, fold the braid over the jacket. If using double braid cables, fold the outer braid over the jacket. Score and remove foil (if applicable). Fold the inner braid over the jacket.</p> 
7	<p>Twist connector to remove from plastic sleeve. Plastic ring may stay attached between connector collar and nut.</p> 

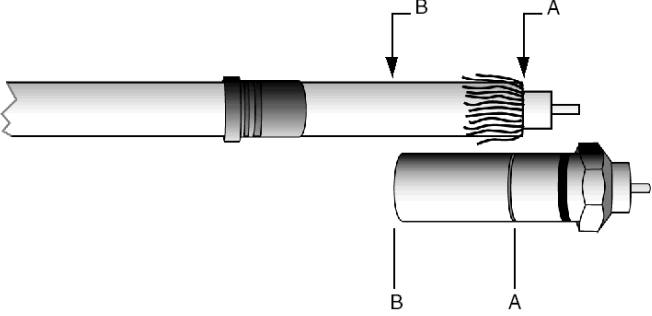
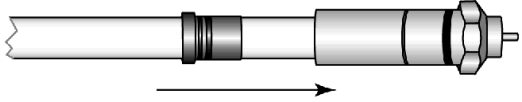
Step	Action
8	<p data-bbox="351 204 1119 282">To determine how far you should insert the cable, place the cable next to the connector as shown. Position the dielectric at the installation groove (point A). With your thumbnail, mark the cable jacket at the edge of the connector (point B).</p>  <p>The diagram shows a cable with a dielectric sleeve and a connector. The cable is positioned next to the connector. Point A is at the groove on the connector, and point B is at the edge of the connector. The dielectric sleeve is aligned with point A.</p>
9	<p data-bbox="351 654 1119 732">Insert cable dielectric into the connector post. Push and twist connector until the cable bottoms inside of the connector (point B should be even with the end of the connector). Push the plastic sleeve into the connector until a snug fit is achieved.</p>  <p>The diagram shows the cable dielectric inserted into the connector post. The connector is pushed and twisted until the cable bottoms inside. The plastic sleeve is pushed into the connector until a snug fit is achieved.</p>

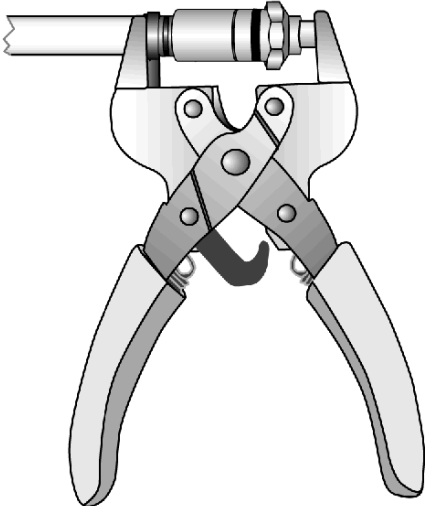
Step	Action
10	<p>Insert connector (with cable) into installation tool #490RIO0C411. Seat plastic sleeve into the pocket of the tool jaw. Squeeze handles together. The black plastic sleeve and the white pin insulator should both snap into place, with the o-ring completely hidden under the collar. The white plastic insulator holding the pin should be below or flush with connector interface.</p>  <p>The diagram shows a pair of pliers-like installation tool #490RIO0C411. A cable is inserted into the tool's jaws. The tool has a central adjustment screw and two long, curved handles. The cable is held between the jaws, and the tool is shown in a closed position, ready to be squeezed together to install the connector.</p>
11	<p>Install the F connector onto the cable port of the RIO drop adapter, tap, or other cable hardware device using a 9/16 in. open-end wrench.</p> <p><b>Note:</b> Finger tightening is not sufficient. Required torque is: 0.8...1.2 N.m (7.1...10.6 lbf-in).</p>

## ***NOTICE***

### **INOPERABLE EQUIPMENT**

Do not tighten the F connector onto the cable port beyond specified torque.

**Failure to follow these instructions can result in equipment damage.**

## Semirigid Cable Connections

### Overview

The following products are recommended for making F connections on a semirigid cable:

- the LRC® two-piece cable adapter, catalog number AI540FMQR made by Thomas & Betts, for the QR 540 JCA cable
- the LRC® three-piece cable adapter, catalog number AI860FMWQR made by Thomas & Betts, for QR 860 JCA cable

Actual cable installation is not trivial because of the cable size and shield material. We recommend that you contact CommScope, the QR series cable manufacturer, for installation tool information, instruction, and assistance.

For interconnection, Thomas & Betts/LRC® and Gilbert Engineering, among others, carry a full line of QR type cable hardware including F adaptors, terminators, and entry hardware.

See *RIO Cable Material Suppliers*, [page 153](#) for contact information for these manufacturers.

### Required Tools

Tools are required to strip the cable aluminum sheath and jacket, core the dielectric, and trim the conductor to the appropriate length to accept the F connector. Two standard 1" or 1 1/2" open end wrenches are used to assemble the connector.

## Semirigid Cable Installation Tools

### Overview

The Ripley Company Cablematic® JCST-QR Jacket Coring Stripping Tool performs all required operations to prepare the recommended cables for connector attachment. Instructions for use and component replacement part numbers are included with this product.

Tool part numbers are:

Cable	Handle (Standard)	Handle (Ratchet)	Coring Bit Kit
QR 540 JCA	JCST 540QR	JCST 540QR-R	CB143K
QR 860 JCA	JCST 860QR	JCST 860QR-R	CB127K

Replacement components are:

Name	Part Number
Jacket Blade	CB6667
Sheath Cutting Blade	CB60

Other Cablematic® tools are available for performing the same functions independently. Insure that the tools purchased apply to the various types of QR cables that are offered.

### Additional Installation Tools

The following are additional installation tools that can be obtained from Cablematic®:

CC-100 Center Conductor Cleaner
CC-200 Center Conductor Scraper
CXC Cable Cutter (0.75 in. maximum)
CXC-1 Cable Cutter (1 in. maximum)



---

## Preparing a Semirigid Cable for a Connector

### Overview

Instructions for use are included with the JCST-QR Jacket Coring Stripping tool. Preparation may be done using a power drill if the ratchet handle has been purchased. A drill adapter is included with this part.

### How to Prepare the Cable

Take the following steps to prepare the semirigid cable for a conductor.

Step	Action
1	Cut the cable, keeping the end as round as possible.
2	Insert the cable into the tool and rotate the tool clockwise with a slight forward pressure. This will remove first the dielectric, then the jacket and sheath.
3	Discard the stripped material and use the cleaner or scraper to remove any remaining dielectric material from the center conductor.

## Installing F Connectors on Semirigid Cable

### Overview

The following procedures are used for installing F connectors on semirigid cable.

**NOTE:** We recommend that you use the two-piece AI540FMQR adaptor for connectorizing QR 540 JCA cable or the three-piece AI860FMWQR adaptor for connectorizing QR 860 JCA cable.

### Two-Piece Connector Installation

Take the following steps for two-piece connector installation. Use 1 in. wrenches for 540 connectors.

Step	Action
1	Remove the clamp nut from the connector and slide it over the prepared cable end until it reaches the bottom inside the ferrule.
2	Insert the cable prepared end over the mandrel until it reaches the bottom.
3	Use a back-up wrench on the end section, tighten the nut firmly to the positive stop connector.

### Three-Piece Connector installation

Take the following steps for three-piece connector installation. Use 1/2 in. wrenches for 860 connectors.

Step	Action
1	Remove the clamp nut from the center housing and slide it over the prepared cable end.
2	Remove the center housing and slide it over the prepared cable end until it reaches the bottom.
3	Insert the cable center conductor into the F connector end piece until it reaches the bottom of the piece while tightening the center housing firmly against the end piece positive stop. Use a back-up wrench on the end piece.
4	Slide the clamp nut to the center housing and tighten firmly against the positive stop. Use a back-up wrench on the center housing.

## Semirigid Trunk Cable Tap Port Connections

### Overview

Taps cannot accept two semirigid cable connectors directly onto the trunk ports because of their large size. To overcome this problem, use the Modicon 90° right angle F adapter, part number 52-0480-000 or Gilbert Engineering part number GF-MF/90 to make the connection.

RG-11 and RG-6 connectors do not have a fit problem and may be connected directly to the tap ports.

## Providing Line Termination on the Drop Cable

### Overview

Drop cables running to J890/J892-00x drop adapters or 410 and 3240 Motion modules require Modicon 60-0513-000 In-line BNC Terminators that allow you to disconnect and reconnect the cable.

**NOTE:** The cables should be labeled at every connection to identify each drop and trunk cable segment. All taps should be labeled with a number that corresponds to the drop number specified in the PLC's I/O Map. Instructional labeling at all in-line termination points on the drop cable promotes proper cable connection and disconnect practices.

### Installing a BNC In-line Terminator on a Drop Cable

Attach a 90° BNC angle connector to the RIO port on the drop adapter, then connect the 60-0513-000 BNC In-line Terminator. Connect the BNC connector on the drop cable to the in-line terminator.

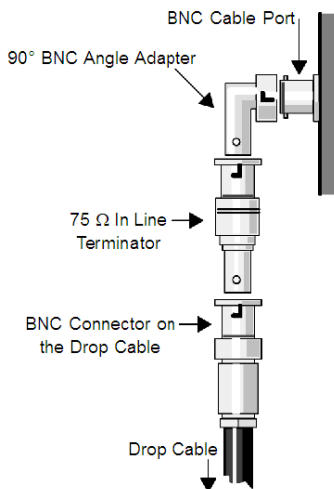

**NOTE:** The 90° BNC angle connector is not available from Modicon. See *RIO Cable Material Suppliers*, page 153 for a list of suppliers.

### Optional Drop Cable In-line Termination

All drop adapters—except those listed in *RIO Network Cable System, page 16*—provide 75  $\Omega$  termination inside the modules themselves. You may want to consider providing the drop cables leading to these adapters with self-terminating F or BNC adapters to assure proper cable termination when the drop adapter is disconnected.

Modicon 52-0370-000 Self-terminating BNC Adapters may be used optionally in cases where self-terminating BNC connections are desired. For RG-6 cable, Modicon 52-0411-000 Self-terminating F Adapters may be used for quad shield drop cable, and Modicon 52-0399-000 Self-terminating F Adapters may be used for non-quad shield drop cable.

### Installing a Self-terminating Adapter on a Drop Cable

Take the following steps to install a self-terminating adapter on a drop cable.

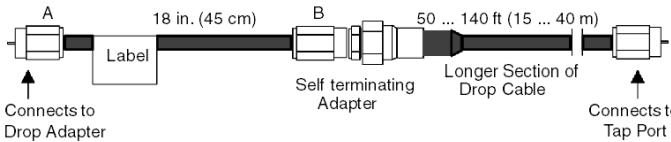
Step	Action
1	Cut the drop cable into two sections, one of which is 18 in. (45 cm) long. Install an F or BNC connector on each end of the 18 in. cable section.
2	Install an F connector on one end of the longer drop cable section and the self-terminating F or BNC adapter on the other end.
3	<p>Connect the 18 in. section of drop cable to the cable port on the RIO drop adapter using the end that has the label attached closer to it (connection point A). Connect the other end of the 18 in section of drop cable to the self-terminating adapter on one end of the longer drop cable (connection point B).</p> 
4	Connect the F connector on the other end of the longer drop cable section to the tap port. The drop connection is now complete.
5	To disconnect the drop from the network while the network is running, disconnect the 18 in drop cable section from the self-terminating adapter (connection point B), then from the drop adapter (connection point A).

## Connecting/Disconnecting a Drop Cable at a Tap

### Overview

None of the three ports on an MA-0185-X00 can be left open while the system is running. Taps that do not have drop cables running from them must be terminated with a Modicon 52-0402-000 Tap Port Terminator.

### Connecting a Drop Cable to an Unused Tap

The following steps demonstrate how to connect a drop cable to an unused tap.

Step	Action
1	Obtain permission from your network manager to stop communications on the network.
2	Disconnect the 52-0402-000 Tap Port Terminator from the drop cable tap port where you want to connect the drop cable. <div data-bbox="329 649 864 974" data-label="Diagram"> <p>The diagram shows a Modicon MA-0185-X00 tap with two ports on the left labeled 'Trunk Cable In' and 'Trunk Cable Out'. On the right, a '52-0402-000 Tap Port Terminator' is shown being disconnected from the tap's drop port. The tap is labeled 'MODICON AN AEG COMPANY' with 'IN' and 'OUT' markings.</p> </div>
3	Connect the F connector on the drop cable to the drop-cable tap port. <div data-bbox="329 1071 974 1396" data-label="Diagram"> <p>The diagram shows the same Modicon MA-0185-X00 tap. The '52-0402-000 Tap Port Terminator' has been removed. An 'F connector' is now connected to the drop port, labeled 'Drop Cable'. The tap is labeled 'MODICON AN AEG COMPANY' with 'IN' and 'OUT' markings.</p> </div>

## Disconnecting a Drop Cable from a Tap

The following procedure demonstrates how to disconnect a drop cable from a tap.

Step	Action
1	Obtain permission from your network manager to stop communications on the network.
2	Disconnect the F connector on the drop cable from the drop-cable tap port.
3	Insert a Modicon 52-0402-000 Tap Port Terminator terminator in the drop-cable tap port.

### CAUTION

#### **Possible Equipment Failure**

Do not connect a drop cable to or disconnect a drop cable from a tap on an ACTIVE network. Either of these two actions can cause excessive communications errors on the network.

**Failure to follow these instructions can result in injury or equipment damage.**

## Installing 140NRP95400 and 140NRP95401C Fiber Optic Repeater Modules

### Observing Safety Precautions

Before installing the fiber optic repeater module, read the warning messages below. Follow them at all times during the installation of the fiber optic repeater.

#### **DANGER**

##### **SEVERE EYE DAMAGE**

Do not view the ends of fiber optic cable under magnification while a transmit signal is present on the cable.

**Failure to follow these instructions will result in death or serious injury.**

#### ***NOTICE***

##### **INOPERABLE EQUIPMENT**

Do not remove the protective coverings from the optical cable port and optical cable tips until immediately fiber cable connection to the cable port.

After removing the protective coverings, never touch exposed parts such as the ferrule.

After connecting the fiber cable, retain the protective coverings for future use.

Do not remove the protective covering from the unused connector.

**Failure to follow these instructions can result in equipment damage.**

### Related Document

See the *Modicon 140NRP95400 and 140NRP95401C Fiber Optic Repeater Modules User Guide*, for more detailed information.

### Before Starting

Prior to install fiber optic repeater module, coaxial cables (*see page 101*) and optic cables must be prepared and installed to the repeater's site with their connectors.

To prepare optic cables:

- Follow the cable manufacturer's recommendations for routing, installing, and testing the cable. Take care when terminating the ends of each fiber optic cable in order to minimize loss of optical signal. Follow the manufacturer's guidelines for installing optical connectors.
- Test the cable for proper attenuation prior to the connection of the fiber optic repeaters. The cable ends should be accessible at each fiber optic installation site. Allow sufficient cable length for a service loop and strain reliefs.
- Label each cable end to facilitate future maintenance.



## Backplane Mounting

Mount the fiber optic repeater module in the Quantum backplane observing general installation requirements. For details, refer to chapter *Hardware Installation (see Quantum, with Concept and ProWORX, Hardware Reference Manual)*.

## Grounding Requirements

Install the ground block to provide earth ground connection even if the RIO cable is removed from the fiber optic repeater module.

In particular when distant RIO equipment have distant grounding connections, additional ground blocks may also be used along the coaxial cables, as required. To ensure that everything works properly is to maintain good equipotentiality between distant RIO equipments using equipotential conductor.

The following figure shows the ground principle to follow:

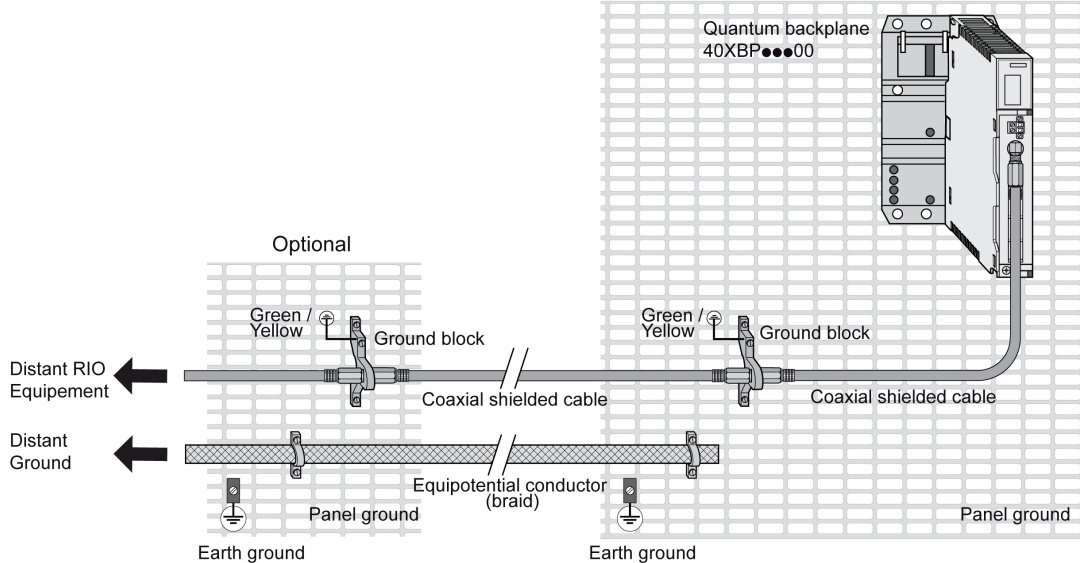

**Distant RIO equipment** Head or drop RIO module

**Distant Ground** This is the ground connection of the head or drop RIO module.

**Optional** Ground blocks may also be used at other ground points along the trunk and drop cables if required.

**NOTE:** The intervals across the total run length of the coaxial shielded cable and the equipotential conductor (braid) must be the smallest possible.

### Installation of the Multimode Fiber Optic Cables

Install the fiber optic cable to the 140NRP95400 module's ST connectors as described in the following table:

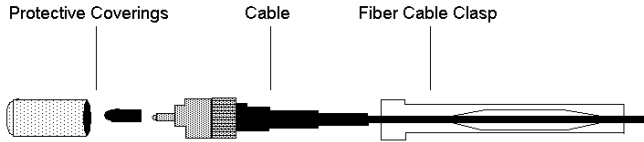
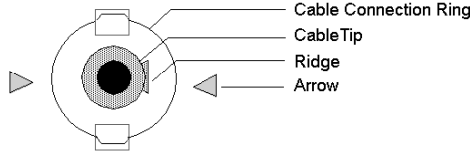
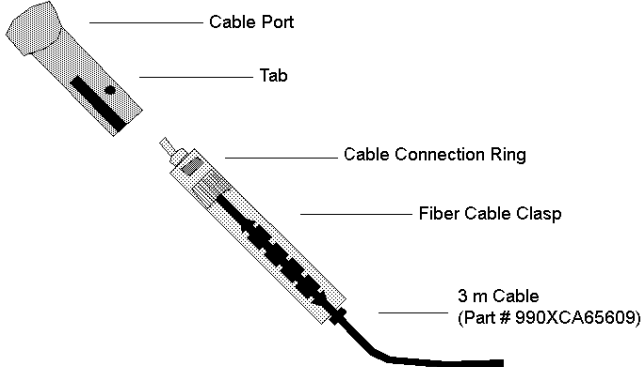
Step	Action
1	<p>Remove the protective plastic coverings from the cable ports and the tips of the cable. Snap one of the fiber cable clasps (shipped with the module) over the cable so that the wider end of the tool is closest to the cable end.</p> 
2	<p>Turn the connection ring so that one of the arrows on the side of the ring lines up with the ridge inside.</p> 
3	<p>a. Slide the tool up to the connection ring.  b. Gripping the cable with the plastic cable clasp, slide the cable end onto the lower cable port. The arrow and the ridge on the connection ring should line up with the slot on the left of the cable port.  c. Use the clasp to push the cable over the tab on top of the port.  d. Turn the cable to the right, so that the tab locks securely  e. Remove the clasp.  f. Repeat this process with the remaining strand of cable.</p> 

## Installation of the Single-mode Fiber Optic Cables

Install the fiber optic cable to the 140NRP95401C module's LC duplex connectors as described in the following table:

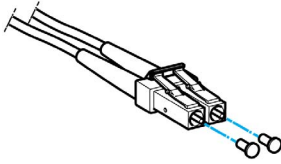
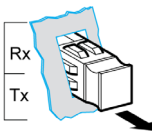
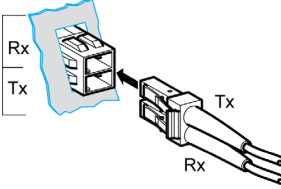
Step	Action
1	<p>Remove the dust plugs from the LC connectors of the fiber optic cable as shown in the following figure:</p>  <p><b>NOTE:</b> Save the dust plugs for future use.</p>
2	<p>Inspect and clean the fiber optic end faces of the LC connectors.</p>
3	<p>Remove the dust plugs from the LC duplex connector as shown in the following figure:</p> 
4	<p>Immediately attach the fiber optic cable to the LC duplex connector of the module as shown in the following figure:</p> 

## Applying Power

Before applying power to the backplane, verify that all power connections (*see Quantum with Unity Pro, Hardware, Reference Manual*), electrical cable connections and fiber optic connections are correctly installed for your application.

When the backplane power is applied to the fiber optic repeater module, the LED Ready will illuminate on the module LED indicators (*see page 92*).

### Reading the Network Indicators

After applying power to the fiber optic repeater, LED indicators (*see page 92*) will illuminate.

The LED ComAct lights when a signal is received at the repeater's electrical port.

Each fiber port LED indicator (FPort1, FPort2) lights when a signal is received at the fiber Rx port.

If a port indicator fails to illuminate, it can indicate a lack of transmitted signal from another network node. Before replacing the fiber optic repeater, check the cable connections for a possible incorrect or loose connection. Also check the indicators on other devices on the signal path to see if the signal loss is external to the repeater. For details refer to the chapter Troubleshooting (*see page 147*).

## Installing 490NRP954 Fiber Optic Repeaters

### Overview

Prior to installing 490NRP954 Fiber Optic Repeaters, fiber optic cable must be installed. Follow the cable manufacturer's recommendations for routing, installation, and testing of the cable. Take care when terminating the ends of each fiber optic cable in order to minimize loss of the optical signal. Follow the manufacturer's guidelines for installing optical connectors. Test the cable for proper attenuation prior to the connection of the fiber optic repeaters.

The cable ends should be accessible at each fiber optic installation site. Allow sufficient cable length for a service loop and strain reliefs. Label each cable end to facilitate future maintenance.

### CAUTION

#### **Possible Equipment Failure**

The RIO network must be powered OFF before installing or replacing a fiber optic repeater.

**Failure to follow these instructions can result in injury or equipment damage.**

### Related Documentation

See the Fiber Optic Repeaters User's Guide, part number GM-FIBR-OPT, for more detailed information on installing fiber optic repeaters.

### Mounting a Repeater

The 490NRP954 Repeater's bottom surface is fitted with pads. Brackets for bolting the unit to a vertical panel are also provided. Your choice of horizontal or vertical mounting should provide access to the device for observing the LED indicators on the front panel and to the rear panel connectors for ease of installation and future servicing.

#### **Horizontal Mounting**

To mount the unit on a horizontal surface, place it at or below eye level to allow viewing the network indicators. Secure it to the surface to prevent it from shifting its position. Do not allow the unit to pull or strain on the network cables and power cable. The mounting brackets supplied with the unit for vertical panel mounting can also be used to secure the unit on a horizontal surface.

#### **Vertical Mounting**

For vertical mounting, use the brackets supplied with the unit for bolting to a panel. The brackets have tabs that insert into slots on the repeater's bottom panel. No additional hardware is required for securing the brackets. You will have to furnish hardware for bolting the repeater brackets to your panel—four bolts are required. Typically, standard ¼-20 (10 mm) bolts are satisfactory.

The repeater's indicators will usually be readable at or slightly above eye level when the unit is installed in the vertical position.

## Connecting the Network Cables

The fiber optic cables should already be run to the site, with connectors installed. If they are not in place, install them using the manufacturer's installation guidelines. Each cable should be labeled to identify the transmit/receive link to which it connects.

Connect the RIO coaxial cable and the fiber optic cables to the repeater's rear panel connectors. Secure the coaxial cable to the F-connector.

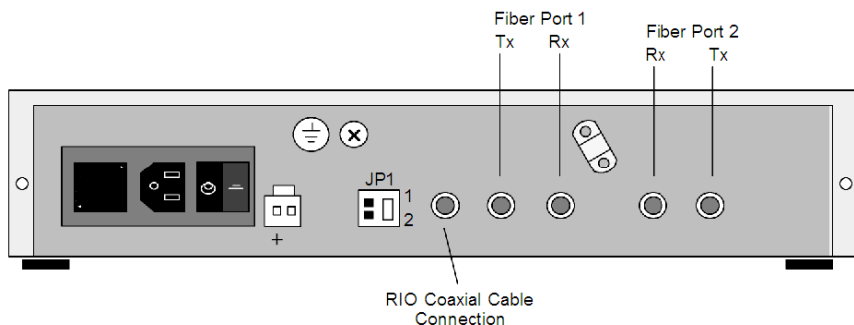

If the network links are active, the **remote I/O** and **fiber port** LEDs on the front panel of the unit will be in a steady ON state, indicating that receive activity is under way (see *490NRP954 Fiber Optic Repeater*, [page 95](#) for details).

## **⚠** WARNING

### **Danger to Personnel**

Do not view the ends of fiber optic cable under magnification while a transmit signal is present on the cable—severe eye damage may result. Use white light only!

**Failure to follow these instructions can result in death, serious injury, or equipment damage.**

## RIO Shield-to-Chassis Jumper

Set the shield-to-ground jumper switch appropriately to specify the repeater's relationship to chassis ground (see *490NRP954 Fiber Optic Repeater*, [page 95](#) for details).

## Connecting Power

The repeater operates either from 110/220 VAC line power or from 24 VDC. The AC and DC power connections are located on the back of the panel.

### Connecting AC Power

The repeater is supplied with an AC power cable 6 ft (2 m) long for use with either 110/120 VAC or 220/240 VAC single-phase power. The power cable connects to a socket on the rear panel. Grounding is supplied through the power cable. The AC power cable is keyed for North American 110/120 VAC power outlets. If necessary, install a different plug on the cable for the power source at your site.

Turn the power switch OFF and remove the AC power cable from the repeater. Set the power selector plug to the 110/120 VAC or 220/240 VAC position for the power source at your site. To do this, remove the power selector plug by prying under its tab with a small screwdriver. Set the plug to the proper voltage position as shown on the plug body, then reinsert it. Insert the power cable into the rear panel connector. Secure the power cable under the strain relief. Plug the cable into the AC power source.

### Connecting DC Power

Your DC power source must supply 1 A at 24 V. Switch the DC source OFF. Connect the source to DC power terminals, observing the proper polarity. Secure the power wiring under the strain relief.

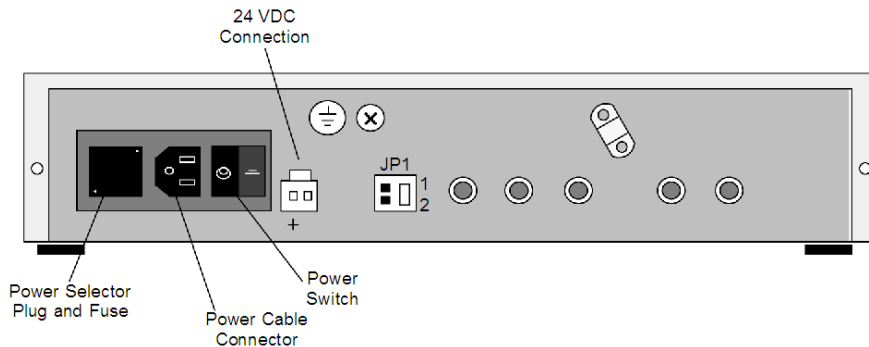

## ⚠ CAUTION

### Possible equipment damage

Fiber optic repeaters cannot be operated with both 115 VAC and 24 VDC power applied at the same time.

**Failure to follow these instructions can result in injury or equipment damage.**

### **Grounding**

The repeater obtains its ground in the AC power cord via the green **gnd** wire or through the DC wire. Using a continuity tester, verify the repeater chassis is grounded to the site ground. To ensure proper grounding, connect the chassis ground to the site ground by direct chassis to ground connection.

### **Applying AC Power**

If you are using AC line power, reapply AC to the fiber optic drop site. The main power switch controls the power to the unit. Set the power switch to the (ON) position. The unit's **power OK** LED will illuminate.

### **Applying DC Power**

If you are using DC power, switch on your DC to the repeater. The unit's **power ok** LED will illuminate.



## Terminating the Trunk Cable

### Overview

The trunk cable must be terminated by inserting a Modicon 52-0422-000 Trunk Terminator in the trunk-out port of the last tap on the RIO network:

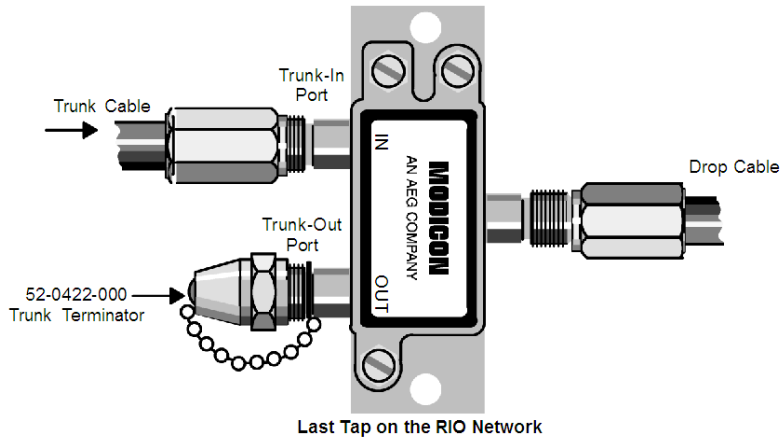

## Installing the Ground Point

### Overview

The cable system should be grounded at a point within 20 ft of the RIO processor at the head-end of the network. A Modicon 60-0545-000 Ground Block, a single Modicon MA-0185-100 Tap, a Modicon MA-0186-100 Splitter, or a Modicon MA-0331-000 Splitter may be used, assuring that the cable system will be permanently grounded even when disconnected from the RIO processor.

**NOTE:** Do not disconnect the cable system from the central ground point—disconnecting the system from ground will create an unfavorable floating ground condition.

A screw is provided on taps, splitters, and ground blocks as the grounding point. If you use a ground block, mount it in a small enclosure.

To install a 60-0545-000 Ground Block:

- Cut the cable
- Install two F connectors on the cable
- Attach two F connectors to the ground block
- Wire the ground block to an appropriate ground (typically building steel)

---

# Chapter 5

## Testing and Maintaining an RIO Network

---

### Overview

This chapter provides information on testing and maintaining an RIO network.

### What Is in This Chapter?

This chapter contains the following topics:

Topic	Page
Maintenance and Testing Requirements	140
Coax RIO System Network Integrity	142
Problem Sources on an RIO Network	144
On-line and Off-line Error Isolation	146
Troubleshooting 140NRP95400 and 140NRP95401C Fiber Optic Repeater Modules	147
Troubleshooting 490NRP954 Fiber Optic Repeaters	149





## Coax RIO System Network Integrity

### Overview

A battery of up to eleven tests can be performed to ensure reliability of the RIO system. These tests are generally performed in the order described below.

RIO network certification services are available from Modicon. Factory authorized personnel qualified to perform certification may be contracted through:

Square D Services - Automation

1960 Research Drive

Troy, MI 48083

Telephone - 1-888-SQUARED

### Fundamental RIO System Tests

Tests 1 ... 7 are the minimum recommended tests for Modicon RIO networks.

#### Test 1 Pre-installation Cable Test

Performed while the cable is still on the reel, this test includes:

- Attenuation sweep test
- Return loss sweep test
- Attenuation measurements test
- TDR test

Modicon and Comm/Scope cables are pretested and do not need to be retested unless shipping damage is suspected or unless you prefer to test all cable on-site before installation.

#### Test 2 Visual Inspection

A check of the entire network including but not limited to:

- Tap installation
- Cable installation
- Cable routing
- Grounding
- Connector installation

#### Test 3 Induced Voltage Test

A check for any potentially hazardous AC voltages on the cable system.

#### Test 4 Grounding Test

A check for potential problems with the cable shields and verify system grounding to a low impedance earth ground.

#### Test 5 Oscilloscope Noise Analysis

Determines the noise level—i.e., whether power spikes are present. Typically the noise level should not exceed 20 mV.

**Test 6 Time Domain Reflectometer (TDR) Test**

Performed on all drop cables and at all trunk end points. It tests the integrity of all drop cables up to and including the tap port, as well as the trunk cable components. Results are produced on a strip chart record with the location of impedance mismatches and the extent of the impedance mismatch. The specification limit for any TDR measurement is determined by the cause of the mismatch.

**Test 7 Attenuation Sweep Test**

Tests the ability of the cable system to pass RIO signals without degradation over the full bandwidth. The test is conducted from the RIO processor node to all trunk and drop end points.

**RIO System Tests for Critical Applications**

Tests 8 ... 10 guarantee performance—if your RIO network is critical to the operation of your process, these tests are highly recommended. They can also be beneficial if your operating environment is extremely noisy.

**Test 8 Attenuation Measurements**

Taken during the attenuation sweep test or using the LMT/LMR attenuation measurement system. This test yields the maximum attenuation on the trunk and on the entire network, end to end. The attenuation should be close to the designed attenuation and must never exceed 35 dB (32 dB for the host-based PLCs).

**Test 9 Return Loss Sweep Test**

A test of reflections on the network. It tests the trunk cable at all end points and at least one drop cable for return loss over the full RIO bandwidth. The return loss on the trunk must be below 16 dB, and below 14 dB on any drop.

**Test 10 Noise Floor Level Test**

Determines the level of noise on the network within the full bandwidth used by RIO. Ensures that the noise floor level is below +10 dBmV over the full RIO bandwidth at any trunk end point and at least one drop cable.

**Network Setup**

The last test should be performed on all startups.

**Test 11 Network Startup**

Tests all the nodes on the network while they are communicating. Communication error counters are monitored over a given time period.

## Problem Sources on an RIO Network

### Overview

Noise on the RIO network is a frequently identified problem source in the troubleshooting process. The symptom is usually excessive retries at the RIO drop adapters. Most noise problems are caused either by inadequate spacing of RIO cable or components from power cables or by an inadequate earth ground. The other common problem source is poor installation.

### Solving Spacing Problems

Spacing problems can frequently be identified in a visual check on the network. Make sure that a spacing of 12 ... 14 in per kV of power is maintained between the cables and components in your RIO system and any type of low to medium power cable.

We recommend that you avoid all power cable including DC power cables. DC power cables pick up spikes from AC power cables and then induce the spikes onto the RIO cable. Even the low power AC cables can induce spikes onto the RIO cable system.

### Potential Grounding Problems

A low impedance earth ground is typically hard to measure properly; even after the measurement is performed, it can be misleading. A properly installed Modicon RIO system is grounded at or near (within 20 ft) the RIO processor at the head-end of the network. The only other condition under which you should ground the network is when the cable enters or exits a building (per NEC code).

If the system is not properly grounded, it will produce excessive retries. We recommend that you connect a separate ground wire from the programmable controller directly to plant ground. The wire should minimally be 14 gauge green or bare wire; solid conductor is preferred. If the controller is grounded only to the panel, make sure the panel wire is sufficient (typically 2 gauge) to handle the load of the panel and that a separate wire is used to ground the panel. Do not use conduit to ground a controller or panel.

Another prevalent grounding problem is with the equipment connected to the controller. When large motors, drives, or spindles are not properly grounded, they cause an excessive amount of EMI/RFI and conduct this noise onto the power system. EMI/RFI interferences are sometimes misinterpreted as programmable controller problems. You should consult with the manufacturer of these products to ensure that they are properly grounded.



### Problems Stemming from Poor Installation

Defective media products can account for some system problems. The main installation problem is usually in the connectors. Using recommended connectors and tools will minimize these kinds of problems.

Installation problems can usually be tracked by performing a visual inspection of the network. You should be able to pull on the F or BNC connections without them falling off. Connectors may also need to be tightened onto the device ports.

Defective media products like cable and taps cannot be seen, and need to be tested using the procedures described in *Coax RIO System Network Integrity*, [page 142](#).

Care should be taken to insure that strands of the shield braid do not short to the coax center conductor. This can occur as a result of the connector installation process.

## On-line and Off-line Error Isolation

### Overview

RIO troubleshooting is a process of isolating problems in an *on-line* system, usually with the aid of LED indicator lamps and system statistics.

Media-related problems are generally solved off-line, not by using LEDs or system statistics. However, once a problem has been isolated to its source using any of the off-line tests described in the last chapter, it is sometimes possible to locate the problem source using the on-line troubleshooting procedures discussed below.

For instance, if a network has passed its sweep and TDR tests but has failed its noise floor test, the network can sometimes be brought up to troubleshoot the source of the noise. By using the retry counters, the noise source can be isolated and the problem corrected. Ineffective grounding of external non-Modicon equipment, ineffective grounding of Modicon equipment, or inadequate spacing of coaxial from power cable can be isolated while the network is on-line.

## Troubleshooting 140NRP95400 and 140NRP95401C Fiber Optic Repeater Modules

### Overview

As a general method, always start investigations by checking the RIO head module transmission propagation through the whole path until reception on each drop. In a second step, connect and check each drop module transmission back to the RIO head.

There are well documented procedures for analyzing the wire side characteristics of RIO network application, and it is recommended that they be used as a first line of attack and afterward whenever trouble is suspected.

The troubleshooting tables in this section cover the most likely encountered issues with 140NRP95400 and 140NRP95401C fiber optic repeater modules.

### Broken Cable Detection and Remedies

Unlike coaxial cable, fiber optic cable contains physically separated transmit and receive lines.

It is possible to lose communications through the receive line while the transmit line remains intact, as depicted here:

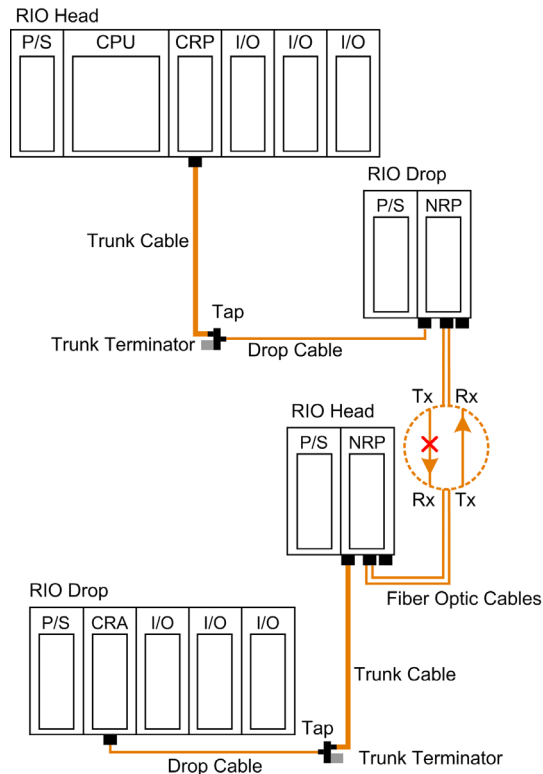

A break in the receive line as shown above will deprive the PLC of input data. Under ordinary circumstances, the PLC will continue to drive outputs via the intact transmit line. This could lead to outputs turning ON or OFF due to invalid (INPUT STATE: 0) input data.

From this fact, it is highly recommended to use a self-healing ring topology, and to monitor the diagnostic relay (*see page 93*) of the fiber optic repeater module.

### Troubleshooting Table

Identify the fact in the left columns and then follow the action to take in response in the right column:

Fact	Diagnostic	Action
All LEDs are OFF.	The fiber optic repeater module is not powered	Check the power supply module
All LEDs are OFF while other modules on the backplane show normal behavior.	Fiber optic repeater module internal loss of power.	Change fiber optic repeater module
Ready LED is OFF.	The internal logic is not available.	Change fiber optic repeater module
Fault LED is ON and the contact of the diagnostic relay are closed.	The relay is not operational.	Change fiber optic repeater module
Fault LED is OFF and the contact of the diagnostic relay are open.	Fault LED or relay is not operational or diagnostic cable is disconnected.	Check diagnostic relay cable integrity. If ok, change fiber optic repeater module
Contact of the diagnostic relay are open and Error LED is ON	An internal failure has been detected. The fiber optic repeater module is not operational.	Change fiber optic repeater module
ComAct LED, and both FPort1, FPort2 LEDs are OFF.	The fiber optic repeater module doesn't detect any activity, and therefore doesn't transmit anything.	Depending on the function of the fiber optic repeater module in RIO network, check where the head communication is supposed to come from. (and checked that the PLC is not in a STOP state)
BrkF LED is ON, Fault LED is ON and the contact of the diagnostic relay are open.	One of the optic fiber reception port doesn't detect activity while the other fiber optic reception port detects or has detected activity.	Check that FPort1 Rx and FPort Rx 2 are connected. Check that the ComAct LED and one FPort• LED is ON. Check which FPort• LED is OFF, and check the associated Rx connector and optical fiber integrity.

## Troubleshooting 490NRP954 Fiber Optic Repeaters

### Overview

Here is a typical point-to-point RIO fiber optic link:

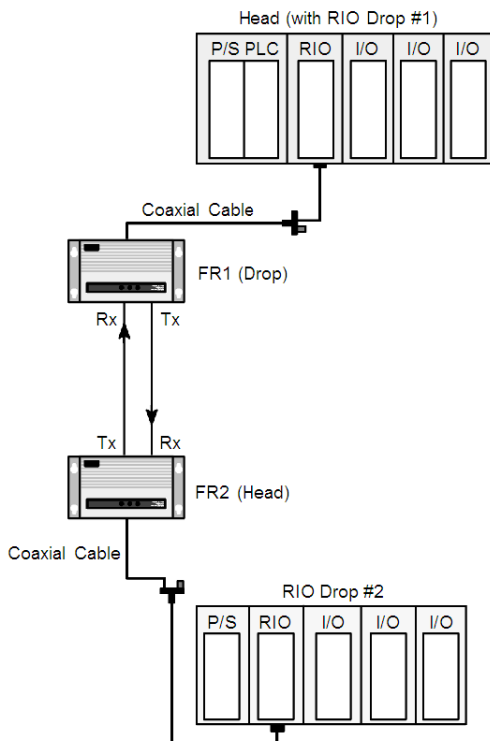

There are well documented procedures for analyzing the wire side characteristics of this type application, and it is recommended that they be used as a first line of attack and afterward whenever trouble is suspected.

If the coaxial system is working properly, it will cause the **remote I/O** LED on FR1 to illuminate. If that LED illuminates as expected, then the **fiber port 1** LED on FR2 should illuminate and the **fiber port 2** LEDs on FR1 and FR2 should be OFF.

If the **fiber port 1** LED on FR2 does not illuminate, check the Tx and Rx connections on the fiber link. If the problem persists, substitute a known good repeater for FR2 and repeat the procedure. If the problem still persists, check the drop adapter and coaxial link at drop #2. If all this still checks out properly, then you have isolated the problem to faulty fiber cable, and manufacturer's test procedures must be used.

## Broken Cable Detection and Remedies

Unlike coaxial cable, fiber cable contains physically separate transmit and receive lines. It is possible to lose communications through the Rx line while the Tx line remains intact. A break in the Rx line will deprive the PLC of input data. Under ordinary circumstances, the PLC continues to drive outputs via the intact transmit line. This could lead to outputs turning ON or OFF due to invalid (INPUT STATE: 0) input data. A method to prevent this from happening uses STAT and SENS instructions in ladder logic to detect the loss of input communication and inhibit improper output state changes:

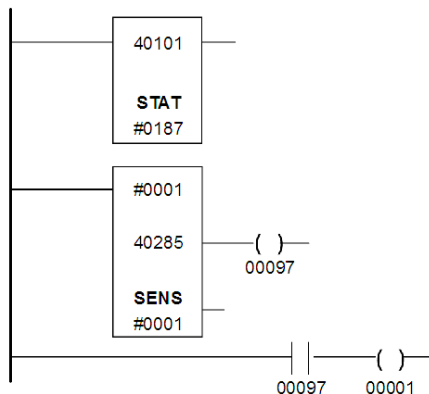

STAT and SENS monitor the I/O status of Drop #2 and inhibit output 00001 if communications are lost. STAT provides access to the system's status, including the status of S908 communications. The status information is stored in a table starting at register 40101 and has a length of 187 words (as shown in the top and bottom nodes of the STAT instruction).

SENS senses the first (communications health) bit (SENS top node value = 1) of the 185th word in the status table (SENS middle node value = 40285). This bit is the communications health for Drop #2 of the S908.

Coil 00001 has been configured as an output in the I/O Map. If the PLC's Rx line is broken, the sensed bit becomes 0 (OFF). The middle node output to coil 00097 is set to 0 (OFF). Coil 00097 controls a normally open relay which, when power is removed, opens the circuits to coil 00001, thus inhibiting this output. The coils can now be used in ladder logic to inhibit specific output writes.

As an alternative, the coil can be used to control a SKP instruction to prevent execution of that portion of the network which would ordinarily output data.

---

# Appendices

---







---

# Appendix A

## RIO Cable Material Suppliers

---

### RIO Cable Material Suppliers

#### RIO Cable Material Suppliers

**Belden Wire and Cable Company**

2200 U.S. Hwy. 27 South

P.O. Box 1980

Richmond, IN 47374

Telephone: (765) 983-5200 or (800) 235-3361

Fax: (765) 983-5294

Website: [www.belden.com](http://www.belden.com)

**CommScope, Inc.**

Digital Broadband Division

P.O. Box 1729

1375 Lenoir-Rhyne Blvd.

Hickory, NC 28603

Telephone: (800) 982-1708

(828) 324-2200

Fax: (828) 328-3400

Website: [www.commscope.com](http://www.commscope.com)

**Relcom, Inc.**

2221 Yew Street

Forest Grove, OR 97116

Telephone: (800) 382-3765

Website: [www.relcominc.com](http://www.relcominc.com)

**Ripley Company**

Cablematic Tool Division  
46 Nooks Hill Road  
Cromwell, CT 06416  
Telephone: (860) 635-2200  
Website: [www.ripley-tools.com](http://www.ripley-tools.com)

**Rostra Tool Company**

30 East Industrial Road  
Branford, CT 06405  
Telephone: (203) 488-8665  
Fax: (203) 488-6497  
Website: [www.rostratool.com](http://www.rostratool.com)

**Square D Services - Automation**

1960 Research Drive  
Troy, MI 48083  
Telephone: (888)-SQUARED  
Website: [www.squared.com](http://www.squared.com)

**Thomas & Betts World Headquarters**

8155 T & B Boulevard  
Memphis, TN 38125  
Telephone: (901) 252-5000  
Website: [www.thomasandbetts.com](http://www.thomasandbetts.com)

**3M Telecom Systems Division**

6801 River Place Blvd.  
Austin, TX 78726-9000  
Telephone: (800) 426-8688  
Website: [www.3m.com/market/telecom](http://www.3m.com/market/telecom)

---

# Glossary

---



## A

**amplitude**

A measure of the strength of a signal.

**application**

A user program

**armor**

A metal wrapping around a coaxial cable used for mechanical protection.

**attenuation**

Signal loss through an electrical circuit or conductor (*see also* **signal loss**).

## B

**bandwidth**

A range of frequencies.

**baseband**

A type of network having a single communications channel. RIO is a baseband communications network.

**bend radius**

The radius of the arc along which a cable may be bent.

**bit error rate**

The number of bits received in an error divided by the total number of bits received.

**braid**

A wire mesh used to construct the shield of a coaxial cable

**bus**

A single cable connecting multiple ports.

## C

**cable shield**

The outer conductor of a coaxial cable used to protect the signal on the cable from noise.

**cable sweep**

A test that assures proper network response within a given frequency range.

**carrier detect**

A status LED indicating the presence of activity on the network.

**CATV**

Community antenna television

**center conductor**

The center wire in a coaxial cable, usually made of copper or copper-clad metal.

**characteristic impedance**

The ratio of signal voltage to signal current on a transmission line.

**coaxial cable**

A type of transmission line having a center conductor surrounded by an insulator (a dielectric), then an outer shield.

**COMM ACTIVE**

A status LED indicating that the modem is communicating.

**COMM ERROR**

A status LED indicating that the modem has detected an error in the message.

**COMM READY**

A status LED indicating that the modem is able to communicate.

**communications**

The transmitting and receiving of messages between nodes (intelligent devices) on the network.

**core**

The center region of a coaxial or fiber optic cable through which the signal is transmitted.

**D**

**data field**

The data portion of a message frame, containing the rudimentary command or data.

**destination address**

The part of the RIO message that defines the address of the destination node.

**dispersion**

The cause of bandwidth limitations in a fiber optic signal. Dispersion causes a broadening of input pulses along the length of the fiber. Three major types are: *mode dispersion* caused by differential optical path lengths in a multimode fiber; *material dispersion* caused by a differential delay of various wavelengths of light in a waveguide material; and *waveguide dispersion* caused by light traveling in both the core and cladding materials in single-mode fibers.

**drop**

An address on the RIO network. *See also node.*

**drop cable**

The cable that runs between a tap in the trunk cable and the connector to the RIO drop adapter at the drop.

**drop loss**

The amount of attenuation (signal loss) in the drop cable and the connector—i.e., between the tap and the node.

**dual cable**

An RIO network topology in which two cable systems are run from the head processor in a PLC to two different groups of drop adapter nodes. A dual cable topology requires dual RIO comm ports in the RIO processor node and a single RIO comm port in each drop adapter. *See also* **redundant cable**.

## E

**earth ground**

A connection to earth, usually through structural steel or water pipes.

**egress**

Signal radiated by the transmission line.

**EMI**

Electromagnetic interference, usually caused by inductive devices such as motors. EMI causes noise that can be radiated in the air or conducted through power lines.

## F

**F connector****fiber**

A thin filament of glass. an optical waveguide consisting of a core and a cladding is capable of carrying information in the form of light.

**fiber optics**

Light transmission through optical fibers for communications or signaling.

**foil**

A mylar-backed aluminum foil used for shield construction on coaxial cable.

**frame**

A message unit, particularly that part between the start delimiter and the end delimiter.

**frame check sequence**

A calculated number sent with a message unit and checked by the receiver to assure message integrity.

## G

### **graded-index**

Fiber design in which the refractive index of the core is lower toward the outside of the fiber core and increases toward the center of the core. It bends the rays inward and allows them to travel faster in the lower index-of-refraction region. This type of fiber provides high bandwidth capabilities.

### **ground**

A common signal return point from various circuit elements.

### **ground block**

An RIO network component that may be used as the single-point ground for the system.

## H

### **HLDC (high level data link control)**

The link layer protocol used on an RIO communications network.

### **Hot Standby System**

A 984 capability in which two identically configured PLCs are connected to the same process via RIO cable systems. One primary PLC controls the process while the other standby constantly monitors the process. If the primary controller fails, the backup controller takes over system control operations.

## I

### **I/O map**

A table in the PLC's user memory that directs I/O data to the proper drop/channel and I/O module.

### **impedance**

*See characteristic impedance.*

### **ingress**

The noise picked up by a transmission line from outside sources.

### **input module**

A device used to connect field inputs. This module mounts into an I/O housing at a drop/channel location.

### **insertion loss**

The amount of signal lost through a device.

**L****LAN (local area network)**

A short-distance data communications network.

**link layer**

The RIO communications layer that assures proper message transmission and reception over the network.

**M****mandrel**

The inner section edge of the F connector. As you look into the F connector, the mandrel is the flat edge; the white dielectric must be aligned to the edge of the mandrel.

**mechanical splicing**

Joining of two fiber optic cables together by mechanical means—e.g., elastometric splicing—to enable a continuous signal.

**media**

Cable system components used to make a network.

**Modbus**

A proprietary Modicon protocol for communicating between Modicon systems and host devices—e.g., computers, data access panels.

**modem (modulator demodulator)**

A device that encodes digital data from a host device to an RF signal transmitted over the network and vice versa.

**multimode fiber**

An optical waveguide in which light travels in multiple modes. Typical core/cladding sizes are 50/125  $\mu\text{m}$ , 62.5/125  $\mu\text{m}$ , and 100/140  $\mu\text{m}$ .

**N****network**

A system consisting of the cable media components and the communication nodes.

**node**

An intelligent unit or option on the RIO network, either an RIO processor or a drop adapter.

**noise**

EMI/RFI generated outside the media by electrical devices and induced on the cable system.

**nondirectional signal**

A signal that is allowed to travel in any possible directions or is not restricted to travel in only one direction.

## O

### **output module**

A device used to connect to field outputs. This module mounts into an I/O housing at a drop/channel location.

## P

### **packet**

A self-contained block of data with specific protocol parameters, which is transmitted over the media. A message can comprise many packets.

### **phase delay distortion**

The difference in arrival time between the higher frequency signals and lower frequency signals over distance. Wave form distortion results from the delay in the arrival of the lower frequency signals. Phase delay increases as the length of the cable medium increases.

### **preamble**

A preset bit pattern at the start of a transmission, allowing other nodes to synchronize with the incoming message.

### **protocol**

An agreed upon set of parameters known to each node that allows the nodes to communicate with each other.

### **pull strength**

The maximum allowable torque that may be used to pull a cable through a conduit or enclosure.

## R

### **redundant cable**

An RIO network topology in which two cable systems are run from the RIO processor in a PLC to the same group of drop adapter nodes. A dual cable topology requires dual RIO comm ports in the RIO processor node and in all the adapters. *See also* **dual cable**.

### **redundant programmable control**

*See* **Hot Standby System**.

### **remote I/O drop adapter**

A node at each remote drop that connects to the coaxial cable system, processes messages from the remote I/O processor, and updates the I/O at the drop. *See also* **node**.

### **remote I/O head processor**

The master node for the RIO network; it processes commands for the PLC, and it sends messages to/receives messages from the adapter nodes on the network.



**repeater**

A device that consists of a transmitter and receiver or transceiver, used to amplify a signal to increase signal length.

**response window**

A finite waiting time from transmission to an expected reply, preventing the system from being locked out by a nonreplying node.

**retransmission**

The resending of a message because transmission error in the message-generating node or a failure to receive the message at a receptor node.

**retry**

*See* **retransmission**.

**retry count**

The number of times the RIO processor has had to retransmit a message.

**return loss**

The amount of signal reflected back toward the signal origin, expressed in dB down from the original signal. Return loss is caused by impedance mismatch; the high the return loss, the better.

**RFI (radio frequency interference)**

Noise caused by another transmitting device.

**RG-11**

A standard coaxial cable type, providing good shielding and medium to low signal loss.

**RG-6**

A standard coaxial cable type, providing good shielding and fair signal loss.

**S****scattering**

A property of glass that causes light to deflect from the fiber and contribute to attenuation on the fiber link.

**self terminating F adapter**

A device used on a drop cable to provide proper termination in the event that the node is disconnected from the drop cable.

**semirigid cable**

A standard coaxial cable with very low loss and maximum shielding over the maximum trunk cable distance.

**sequence number**

Part of the RIO message sent over the medium so that the nodes can track packet numbers in the event that a packet retransmission becomes necessary.

**shield**

The outer conductor of a coaxial cable that protects the message transmission on the cable from noise.

**shield effectiveness**

Measured in dB—the higher the value, the better the cable shield.

**signal loss**

The amount of signal lost through media devices. *See also* **attenuation**.

**single-mode fiber**

Unlike the multimode, single-mode fiber does not take multiple paths. The single light beam is transmitted down the fiber and does not interact with the cladding/core boundary. Typical core/cladding size (measured in microns) is 9/125.

**spectrum analyzer**

A device used to test the medium's ability to transmit within a frequency range. It shows signal amplitude on the y-axis and frequency measurement on the x-axis.

**star coupler**

Optical component that allows emulation of a bus topology in fiber optic systems.

**start frame delimiter**

A preset octet pattern marking the start of the message packet.

**sweep generator**

A test device for checking the amplitude integrity of a medium over the bandwidth of RIO signals. It generates a user-specified output signal at a user-specified frequency.

**T**

**tap**

A passive device used to isolate a node from the trunk cable. It allows only a portion of the signal to be transmitted through a port on the tap.

**tap insertion loss**

The amount of signal loss in the trunk caused by inserting a tap.

**TDR (time domain reflectometer)**

A test device for measuring the integrity of a medium regarding impedance mismatch and connections.

**terminator**

A piece of hardware containing a 75  $\Omega$  resistor, used at the ends of the trunk cable, at each node, and at each tap outlet to match the characteristic impedance of the cable. *See also* **characteristic impedance**.

**through loss**

The signal loss through a device caused by physical insertion of the device in the trunk cable. *See also* **insertion loss**.

**topology**

The complete media specification. The topology should be mapped into a log with all installation details for future reference.

**transfer impedance**

A measure of cable's ability to reject noise. The lower the number, the better the cable.

**trunk cable**

The main cable running from the RIO processor upon which taps are installed, permitting the drop adapters to connect to the cable system.

**trunk terminator**

A precision terminator used at the two ends of the trunk cable. *See also* **terminator**.

**V****velocity of propagation**

The speed of the signal in the cable, expressed as a percentage of the speed of light in free space.

**VSWR (voltage standing wave ratio)**

The measure of the signal reflected back from a transmitted signal. Lower ratios indicate better impedance match and cause less signal to be reflected back at the transmitting source.

**W****wavelength**

The distance between the same point on adjacent waves.

**Z****zero crossing**

The condition when the wave form crosses 0 V, either on a voltage rising or on a voltage falling. *See also* **phase continuous signaling**.





## 0-9

- 043509432 Crimp Tool
  - for RG-6 connectors, *103*
  - illustration, *105*
- 043509446 BNC Connector
  - for quad shield, *81*
- 140NRP95400 multimode fiber optic repeater module, *90*
- 140NRP95401C single-mode fiber optic repeater module, *90*
- 490NRP954 Fiber Optic Repeater
  - communication between two or more RIO nodes, *95*
  - horizontal mounting, *133*
  - LEDs illustration, *96*
  - vertical mounting, *133*
- 490RIO00211 F Connector
  - connecting RG-11 cable, *113*
  - for RG-11 cable, *48*
- 490RIO00400 Installation Tool
  - for RG-6 cable, *104*
  - for RG-6 connectors, *103*
- 490RIO00406 Installation tool
  - replacement blade packs, *104*
- 490RIO0211 F connector
  - for RG-11 cable, *78*
- 490RIO0C411 Installation tool
  - installing connectors on RG-11 cable, *118*
- 490RIO0S411
  - stripping RG-11 cable, *114*
- 52-0370-000 Self-terminating BNC Adapter
  - optional use, *125*
  - use in Hot Standby systems, *84*
- 52-0399-000 Self-terminating F Adapter
  - illustration, *85*
- 52-0402-000 Tap Port Terminator
  - disconnecting from port, *126*
  - terminating splitter ports, *76*
  - terminating unused drop connectors, *83*
  - terminating unused ports, *74*

- 52-0411-000 Self-terminating F Adapter
  - illustration, *85*
- 52-0422-000 Trunk Terminator
  - terminating a trunk cable, *52*
  - terminating trunk cable, *83, 137*
- 52-0480-000 Right Angle F Adapter
  - for semirigid cable, *48, 80*
- 52-0487-000 BNC Connector
  - for non-quad shield, *81*
- 52-0614-000 F-to-BNC Adapter
  - illustration, *82*
- 52-0724-000 Jack to Male F Connector
  - illustration, *82*
- 60-0513-000 BNC In-line Terminator
  - running drop cables to, *124*
  - terminating end of drop cable, *84*
- 60-0544-000 Crimp Tool
  - for RG-6 connectors, *103*
- 60-0545-000 Ground Block
  - description, *87*
  - illustration, *87*
  - installing, *138*
- 60-0558-000 Cable Cutters
  - for RG-6 connectors, *103*
- 600-558-000 Cable Cutters
  - illustration, *105*

## A

- AS-MBII-003 Pre-assembled Drop Cable
  - 50 ft length, *68*
- AS-MBII-004 Pre-assembled Drop Cable
  - 140 ft length, *68*

## attenuation

- bandwidth, *71*
- cable type, *53*
- calculation equation, *54*
- calculation example, *55*
- description, *53*
- maximum in RIO networks, *45*
- minimum distance between repeaters, *57*
- on fiber optic link, *57*
- on point-to-point optical link, *58*
- parameters, *71*
- tap, *53*
- typical coaxial cable losses, *45*

**B**

## bend radius

- for coaxial cables, *44*

## BNC connector

- for J890 adapter, *61*
- for RG-6 cable, *81*
- illustration, *81*
- procedure for installing, *111*

## broken cable

- detecting, *150*

## bus topology

- using fiber optic repeaters, *36*

**C**

## coaxial cable

- bend radius, *44*
- choices for RIO network, *42*
- connecting, *134*
- construction, *42*
- environmental considerations, *44*
- pull strength, *44*
- support, *44*

coaxial cable system, hardware components, *73*

## connectors

- for RG-6 cable, *103*

**D**

## drop adapter

- switches, *15*

## drop address

- description, *15*

## drop cable

- description, *16*
- pre-assembled, *68*
- procedure for connecting to an unused tap, *126*
- procedure for disconnecting from a tap, *127*

## drop repeater

- on a fiber optic link, *35*

## dual cable topology

- description, *22*
- illustration, *22*

**E**

## electromagnetic interference

- avoiding, *47*

## EMI/RFI guidelines

- avoiding interference, *47*
- avoiding power wires, *47*
- equipment cabinets or panels, *47*
- high noise environments, *47*
- minimum bend radius and pull strength, *47*
- spacing between power cables, *47*

## environmental considerations

- for coaxial cables, *44*

**F**

## F adapters

- for semirigid cable, *80*

## F connector

- description, *78*
- for quad shield RG-11 Cable, *78*
- for quad shield RG-6 cable, *78, 108*
- for semirigid cable, *79*
- installation procedures, *108*

## F-to-BNC Adapter

- for RG-11 cable, *81*

fiber optic cable  
  connecting, *134*  
Fiber Optic Repeater  
  alternative communication link, *72*  
fiber optic repeater  
  connecting AC power to, *135*  
  connecting DC power to, *135*  
  troubleshooting, *149*  
Fiber Optic Repeater  
  use in RIO cable topology, *33*  
field adapter kits  
  description, *14*

## G

ground blocks  
  description, *87*  
  for RIO network, *138*  
  installing, *138*  
grounding  
  description, *50*  
  low impedance earth ground, *50*  
  protection from lightning, *51*  
  use of surge suppressors, *51*

## H

hardware components  
  optional equipment, *72*  
  part numbers, *73*  
head repeater  
  on a fiber optic link, *35*  
Hot Standby cable topology  
  description, *24*  
Hot Standby systems  
  self-terminating BNC adapters, *84*

## I

illegal coaxial cable topologies  
  examples, *30*  
illegal drop cable connections, *32*  
illegal trunk cable  
  connections, *31*  
  termination illustration, *30*

impedance  
  of network components, *45*  
Installing BNC connectors  
  on RG-6 cable, *111*  
Installing BNC in-line terminator  
  on a drop cable, *124*  
installing coaxial cables  
  overview, *102*  
Installing self-terminating F connectors  
  on RG-6 cable, *111*

## L

linear cable topology  
  description, *20*

## M

MA-0185-000 Tap  
  Revision C, *75*  
MA-0185-100 Tap  
  attenuation, *56*  
  description, *74*  
  specifications, *75*  
MA-0186-100 splitter  
  description, *76*  
  Revision B, *77*  
  specifications, *77*  
MA-0329-001 F Connector  
  for quad shield RG-6 cable, *78*  
  for RG-6 cable, *48*  
MA-0329-001 F Connector Cassette  
  for quad shield RG-6 cable, *108*  
MA-0331-000 splitter  
  description, *76*  
  illustration, *76*  
  specifications, *77*  
multimode fiber optic links  
  recommended connectors, *99*  
  recommended light sources, *99*  
  recommended materials, *99*  
  recommended power meters, *99*  
  recommended termination kits, *99*

**O**

- open taps
  - terminating, *31*

**P**

- point-to-point topology
  - using fiber optic repeaters, *35*
- pull strength
  - for coaxial cables, *44*

**R**

- radio frequency interference avoiding, *47*
- redundant cable topology
  - description, *21*
  - illustration, *21*
- redundant Hot Standby cable
  - illustration, *26*
- remote drops
  - connecting, *30*
- return loss
  - avoiding, *46*
  - in a coaxial cable system, *46*
- RG-11 cable
  - characteristics, *43*
  - installing, *102*
  - noise immunity, *61*
  - Plenum-equivalent cable, *69*
  - procedure for installing F connectors, *115*
  - required tools for connecting, *113*
  - specifications, *69*
  - stripping, *114*
- RG-11 installation tool
  - replacement blade pack, *114*
- RG-6 cable
  - attenuation characteristics, *53*
  - characteristics, *43*
  - equivalent cable, *68*
  - installation tool, *104*
  - installing, *102*
  - specifications, *68*
- RIO adapter
  - connecting drop adapters, *61*

- RIO cable shield-to-chassis jumper
  - illustration, *96*
- RIO cable system
  - designing, *40*
  - key elements, *40*
  - required hardware components, *72*
- RIO drops
  - documenting, *62*
  - minimizing low receive signal level problems, *62*
  - planning, *61*
- RIO head
  - description, *13*
- RIO media components
  - characteristic impedance, *45*
- RIO network
  - device types, *18*
- RIO network cable
  - terminating, *16*
- RIO network communications
  - advantages, *12*
  - data transfer, *12*
  - description, *12*
  - message transmission, *12*
- RIO processor
  - description, *13*

**S**

- self-healing ring topology
  - using fiber optic repeaters, *38*
- Self-terminating adapter
  - procedure for installing on drop cable, *125*
- Self-terminating F connectors
  - procedure for installing, *111*
- semirigid cable
  - characteristics, *43*
  - installing F connectors on, *122*
  - preparing for a connector, *121*
- single cable Hot Standby
  - illustration, *25*
- single cable linear topology
  - illustration, *20*
- splitter
  - description, *16*



- star topology
  - not allowed in coaxial cable system, *31*
- STAT and SENS instructions
  - detecting loss of communications, *150*
- structural support
  - for coaxial cables, *44*
- surge suppressors
  - for networks exposed to lightning, *88*
  - illustration, *88*
- system expansion
  - design considerations, *41*

## T

- taps
  - connecting with semirigid cable, *123*
  - description, *16*
  - enclosure considerations, *49*
  - placement, *48*
  - port connections, *48*
  - port types, *48*
- terminating
  - drops, *52*
  - trunk cables, *52*
  - unused tap ports, *52*
- terminators
  - power-handling capability, *83*
- three-piece connector
  - installing, *122*
- tree topology
  - using fiber optic repeaters, *37*
- trunk cable
  - band markings, *48*
  - types, *16*
- trunk splitter
  - illustration in Hot Standby system, *29*
  - illustration in standalone system, *28*
  - use in Hot Standby system, *29*
  - use in standalone system, *28*
- two-piece connector
  - installing, *122*

